

Wall-mounted, vertical

OKHE 80, OKHE 100, OKHE 125, OKHE 160

ELECTRIC storage water heater
for vertical mounting



- 1 Temperature indicator
- 2 Heating element container
- 3 **DRY CERAMIC HEATING ELEMENT**
- 4 Operating thermostat with external control
Safety thermostat
- 5 Cover for electrical equipment
- 6 Filling pipe for cold water
- 7 Adjusting screw
- 8 Holder for operating and safety thermostat
- 9 Discharge pipe for hot water
- 10 Mg anode
- 11 Enamelled steel tank
- 12 Polyurethane CFC-free insulation
- 13 Heater casing

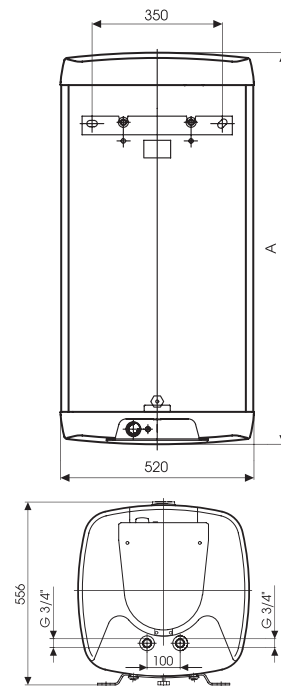
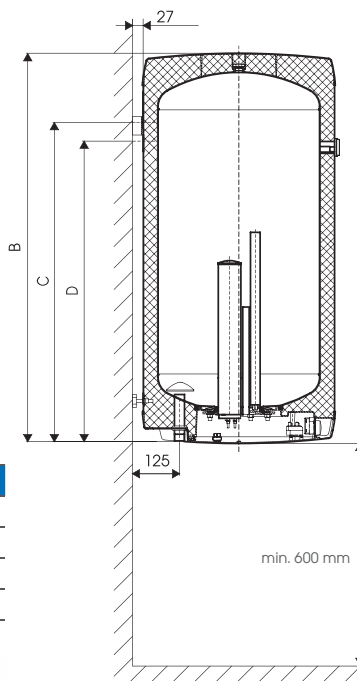
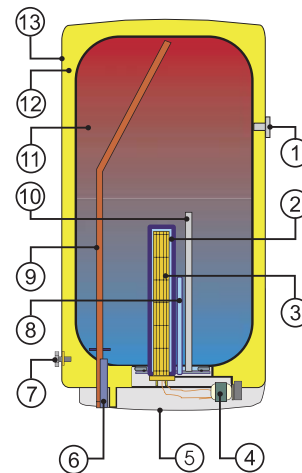

Type	OKHE 80	OKHE 100	OKHE 125	OKHE 160
A	742	887	1052	1237
B*	737	882	1047	1232
C	610	700	850	1050
D	560	650	800	1000

*Height from the upper edge of the heater to the end of the water inlet and outlet pipes.

Thanks to the increased thickness of the thermal insulation (an average of 55 mm) the heaters have very low heat loss, which puts them into energy efficiency class B.

Type	OKHE 80	OKHE 100	OKHE 125	OKHE 160
Volume (l)	80	100	125	152
Nominal overpressure (MPa)	0.6	0.6	0.6	0.6
Voltage (V/Hz)	1 PE-N 230/50	1 PE-N 230/50	1 PE-N 230/50	1 PE-N 230/50
Connected load (kW)	2	2	2	2
Electrical protection	IP 45	IP 45	IP 45	IP 45
Height x width (mm)	742x520	887x520	1052x520	1237x520
Maximum weight of heater without water (kg)	37	42	49	57
Heating period with ele. en. from 10 °C to 60 °C (hour)	2,5	3	3,8	5
Heat loss/energy efficiency class (kWh/24 h)	0.55/B	0.7/B	0.87/B	1.05/B

All types of heaters can be made to order with a heating element with 4000 W and 3PE-N 400V/50Hz connection. Heating time is decreased to half the value stated in the table.