

Operation and Installation Manual



Storage Tanks Type NADO

Družstevní závody Dražice – strojírna s.r.o. (*Works Cooperative - Dražice – Machine Plant, Ltd.*)

Dražice 69

29471 Benátky nad Jizerou

Tel.: 326 370911, fax: 326 370980

www.dzd.cz

dzd@dzd.cz

EN – Operation & Fitting Instructions

1. Description

Accumulation tanks serve accumulation of excessive heat from its source. The source may be a solid fuel boiler, heat pump, solar collectors, fireplace inserts, etc. Some types of tanks allow combination of connecting even multiple sources.

The NADO type tanks serve accumulation of heat in the heating system and allow heating or preheating of HSW (Hot Service Water) in an inner tank. Incorporation of an accumulation tank in the heating system with a solid fuel boiler allows an ideal run of a boiler at favourable temperature during the boiler operation. The main benefit lies in the period of optimum operation (i.e. with maximum efficiency) when the excessive unconsumed heat accumulates in the tank.

The tanks and potential tubular exchangers are made of steel, without the inner surface treatment, the outer surface of the tank is provided with a protective paint. The tanks are equipped with a removable 100 mm thick Symbio insulation made of polyurethane sheet. The tanks are manufactured in 500, 700 and 1000-litre volumes. Individual versions are additionally equipped with one or two tubular exchangers, each of 1.5 m² area and an inspection hole of 182 mm clearance with an option of installation of an in-built electric heating unit TPK.

The NADO type enables direct heating of HSW (Hot Service Water) in an inner enamelled tank, or its preheating for next water heater. Connection to a boiler usually allows direct HSW heating in the inner tank to the desired temperature whilst, on the contrary, connection to solar collectors or heat pump only preheats HSW and another, e.g. electric, heater has to be used, in order to complete heating the water to the desired temperature, or final electric heating has to be fitted in the accumulation tank which is enabled either by the electric heating unit TJ 6/4“, or by the heating flange TPK.

2. General dimensions

Capacity (l)	Diameter (mm)	Height (mm)
500	600	1990
750	750	2020
1000	850	2053

3. Description of individual versions

NADO v1

Accumulation tank with a flange of 210 mm screw spacing. The flange can be used for assembly of an in-built electric heating TPK flange unit. In the standard version, the flange is blinded. The delivery includes insulation of 100 mm thickness. The tank contains an inner enamelled accumulator of 100, 160 or 200 litre capacity, depending on the size of the accumulation tank.

NADO v2

Accumulation tank with a flange of 210 mm screw spacing for the assembly of an in-built electric flange heating unit TPK and one exchanger of 1.5 m² area for connection of an additional heating system (e.g. SOLAR). In the standard version, the flange is blinded. The delivery includes insulation of 100 mm thickness. The tank contains an inner enamelled accumulator of 100 or 140 litre capacity, depending on the size of the accumulation tank.

NADO v3

Accumulation tank with a flange of 210 mm screw spacing for the assembly of an in-built flange electric heating unit TPK and two exchangers, either of 1.5 m² area for connection of an additional heating system (e.g. SOLAR). In the standard version, the flange is blinded. The delivery includes insulation of 100 mm thickness. The tank contains an inner enamelled accumulator of 100 litre capacity, depending on the size of the accumulation tank.

4. Illustration of NADO versions and description of outlets

NADO v1

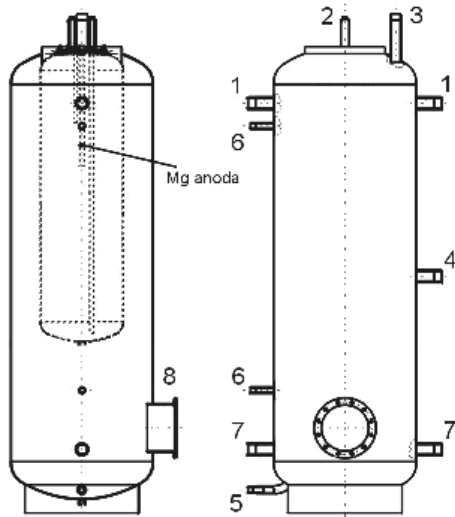

Outlets:

- | | |
|--|-------------|
| 1. water inlet to accu. tank | inner G5/4" |
| 2. HSW accumulator inlet and outlet | outer G1/2" |
| 3. hot water accumulator outlet (bleeding) | outer G1" |
| 4. next inlet | inner G5/4" |
| 5. water inlet to accu. tank (drain) | outer G1" |
| 6. thermowells (thermometer, thermostat) | inner G1/2" |
| 7. water outlet from accu. tank (return water) | inner G5/4" |
| 8. flange, right 210 for assembly of TPK | |

NADO v2

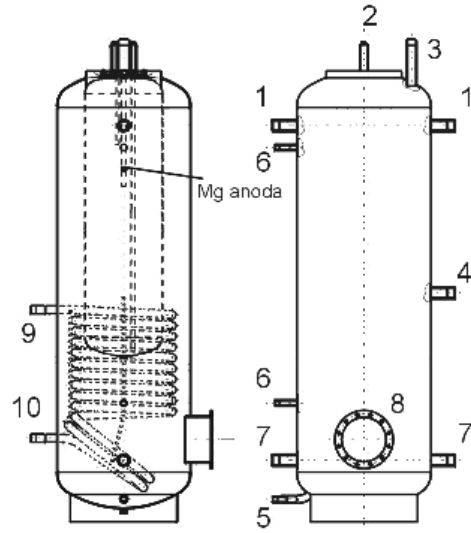

Outlets:

- | | |
|--|-------------|
| 1. water inlet to accu. tank: | inner G5/4" |
| 2. HSW accumulator inlet and outlet | outer G1/2" |
| 3. hot water accumulator outlet (bleeding) | outer G1" |
| 4. next inlet | inner G5/4" |
| 5. water inlet to accu. tank (drain) | outer G1" |
| 6. thermowells (thermometer, thermostat) | inner G1/2" |
| 7. water outlet from accu. tank (return water) | inner G5/4" |
| 8. flange, right 210 for assembly of TPK | |
| 9. heating water inlet | inner G1" |
| 10. hot water outlet | outer G1" |

NADO v3

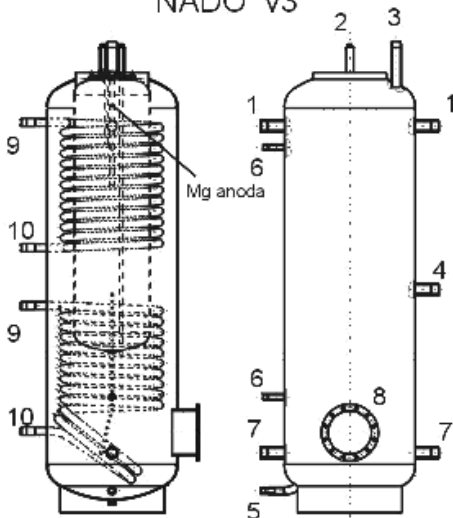

Outlets:

- | | |
|--|-------------|
| 1. water inlet to accu. tank | inner G5/4" |
| 2. HSW accumulator inlet and outlet | outer G1/2" |
| 3. hot water accumulator outlet (bleeding) | outer G1" |
| 4. next inlet | inner G5/4" |
| 5. water inlet to accu. tank (drain) | outer G1" |
| 6. thermowells (thermometer, thermostat) | inner G1/2" |
| 7. water outlet from accu. tank (return water) | inner G5/4" |
| 8. flange, right 210 for assembly of TPK | |
| 9. heating water inlet | outer G1" |
| 10. hot water outlet | outer G1" |

NADO v2 - with inner vessel 140 l

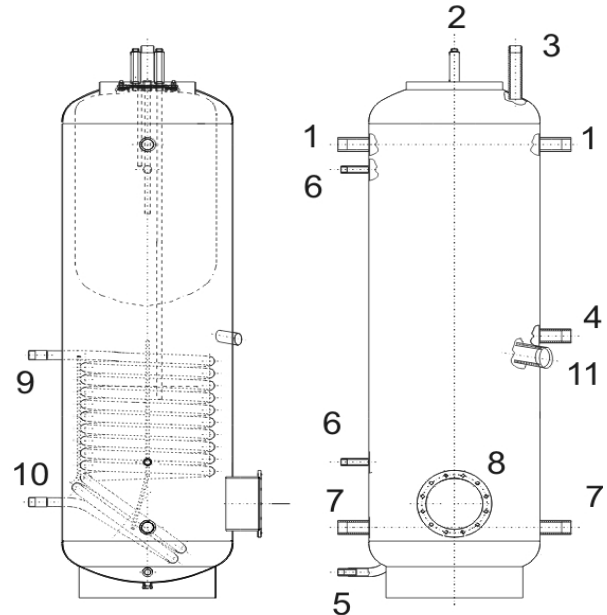

Outlets:

- | | |
|---|---------------|
| 1. water inlet to accu tank | inner G5/4" |
| 2. HSW accumulator inlet and outlet | outer G3/4" |
| 3. hot water accumulator outlet (bleeding) | outer G1" |
| 4. next inlet | inner G5/4" |
| 5. water inlet to accu tank (drain) | outer G1" |
| 6. thermowells (thermometer, thermostat) | inner G1/2" |
| 7. water outlet from accu tank (return water) | inner G5/4" |
| 8. flange, right 210 for assembly of TPK | |
| 9. heating water inlet | outer G1" |
| 10. hot water inlet | outer G1" |
| 11. inlet for electric heating TJ | inner G1 1/2" |

5. Designing the size and connection of ACCU tank to the heating system

An ideal size of the accumulation tank is designed by a design engineer, or a person sufficiently qualified to design heating systems.

Product assembly must be implemented by an authorised person (confirmed in the warranty certificate).

Prior to commissioning, we recommend that you run the heating circuit and any impurities that are trapped in the filter clean, then the system is fully operational.

6. General Technical Parameters

The maximum operating pressure in the tank is 0.3 MPa. The maximum heating water temperature in the tank is 90°C. The maximum operating pressure in the inner tank is 0.6 MPa. The maximum hot service water temperature in the inner tank is 90°C.

In version 2 a 3 additionally:

The maximum operating pressure in the exchanger is 1 MPa, the maximum temperature of heating water in the exchanger is 110°C.

Important: When putting into operation, water has to be filled first into the inner tank for HSW and the operating pressure inside it has to be kept, only then heating water can be filled into the outer accumulation tank, otherwise the product may get damaged!

The manufacturer explicitly emphasises the necessity of being particular in testing the tightness of the heating circuit (radiators, piping joints, floor heating, etc.) with the connection of the accumulation tank. No pressure grow in the accumulation tank heating water compartment may occur above the maximum operating pressure of 0.3 MPa, if the heating system is pressurised to higher than the maximum operating pressure, the inner enamelled tank may get permanently damaged!

No stop fitting can be put between the security fitting of the heating circuit and the accumulation tank!!!

It is recommended to use the product in an indoor environment with air temperatures from +5°C to 45°C and a maximum relative humidity of 80%.

Safety valve has to be fitted on the cold water inlet. Each hot service water pressure heater must have a safety valve with a membrane spring. Nominal clearance of safety valves is defined in the ČSN 0 60830 standard. The heaters are not equipped with a safety valve. The safety valve must be easily accessible, as close to the heater as possible. The input pipes must have at least the same clearance as the safety valve. The safety valve is placed high enough to secure dripping water drain by gravity. We recommend mounting the safety valve onto a branch pipe. This allows easier exchange without having to drain the water from the heater. Safety valves with fixed pressure settings from the manufacturer are used for the assembly. Starting pressure of a safety valve must be identical to the maximum allowed heater pressure, and at least 20% higher than the maximum pressure in the water main. If the water main pressure exceeds such value, a reduction valve must be added to the system. No stop valves can be put between the heater and the safety valve. During the assembly, follow the guide provided by the safety equipment manufacturer. It is necessary to check the safety valve each time before putting it into operation. It is checked by manual moving of the membrane from the seat, turning the make-and-break device button always in the direction of the arrow. After being turned, the button must click back into a notch. Proper function of the make-and-break device results in water draining through the safety valve outlet pipe. In common operation, such a check needs to be implemented at least once a month, and after each heater shutdown for more than 5 days. Water may be dripping off the drain pipe of the safety valve; the pipe must be open into the air, pointed down; environment temperatures must not drop below zero.

When draining the heater, use a recommended drain valve. First, close water input into the heater.

Find necessary pressure values in the following table.

Safety valve starting pressure (MPa)	Admissible operating water heater pressure (MPa)	Max. pressure in the cold water pipe (MPa)
0.6	0.6	do 0.48
0.7	0.7	do 0.56
1	1	do 0.8

For proper safety valve operation, a backflow valve must be mounted on the inlet pipes, preventing spontaneous heater draining and hot water penetrating back into the water main.

We recommend that the hot water distribution from the heater was as short as possible to minimise heat losses.

Heaters must be provided with a discharge valve mounted on the cold service water inlet to the heater for potential disassembly or repair.

When assembling the security equipment, follow ČSN 06 0830.

We recommend checking and cleaning the tank from scale and eventual replacement of the anode rod after two years of operation. The anode life is theoretically calculated for two years of operation; however, it changes with water hardness and chemical composition in the place of use.

Thermal insulation

Polyester sheet of 100 mm thickness. It consists of an upper cover, flange cover and hole caps. Insulation is supplied in a separate packaging.

We recommend that the insulation was fitted at room temperature.

At temperatures significantly below 20°C the insulation shrinks. This disables its easy fitting.

