

OPERATING AND INSTALLATION MANUAL

ELECTRIC ACCUMULATION WATER HEATER TO - 20



Družstevní závody Dražice-strojírna s.r.o.
(Works Cooperative - Dražice - Machine Plant, Ltd.)
Dražice 69, 294 71 Benátky nad Jizerou
tel.: +420 / 326 370 911
fax: +420 / 326 370 980
e-mail: export@dzd.cz



CONTENTS

1	TECHNICAL SPECIFICATION OF PRODUCT	4
1.1	FUNCTION DESCRIPTION	4
1.2	ADVICE FOR CUSTOMERS	4
1.2.1	HOT WATER CONSUMPTION	4
1.2.2	ENERGY SAVING	4
1.2.3	EMERGENCY POWER CONSUMPTION	4
1.3	DESIGN AND GENERAL HEATER DIMENSIONS.....	5
2	OPERATION AND FITTING INSTRUCTIONS.....	6
2.1	OPERATING CONDITIONS	6
2.2	WALL MOUNTING.....	6
2.3	PLUMBING FIXTURE.....	8
2.4	ELECTRIC WIRING	10
2.4.1	ELECTRIC INSTALLATION GENERAL INFORMATION.....	10
2.5	FIRST HEATER COMMISSIONING	10
2.6	PUTTING OUT OF SERVICE, DISCHARGE	11
2.7	INSPECTION, MAINTENANCE & CARE FOR THE APPLIANCE	12
2.8	MOST FREQUENT FUNCTION FAILURES AND THEIR CAUSES	13
3	IMPORTANT NOTICES	13
3.1	INSTALLATION REGULATIONS.....	13
3.2	DISPOSAL OF PACKAGING MATERIAL AND FUNCTIONLESS PRODUCT	14
4	PRODUCT ACCESSORIES	14

READ CAREFULLY THE BELOW INSTRUCTIONS PRIOR TO THE INSTALLATION THE HEATER!

Dear Customer,

The Works Cooperative of Dražice - Machine Plant, Ltd., would like to thank you for your decision to use a product of our brand. With this guide, we will introduce you to the use, construction, maintenance and other information on electrical water heaters.



The manufacturer reserves the right for engineering modification of the product. The product is designed for permanent contact with drinkable water.

It is recommended to use the product in indoor environment with air temperatures from +2°C to 45°C and a relative humidity up to 80%.

Product's reliability and safety is proven by tests implemented by the Engineering Test Institute in Brno.

Made in the Czech Republic.

Meaning of pictograms used in Manual



Important information for heater users.



Recommendations of manufacturer, observance of which will ensure trouble-free operation and long service life of the product.



CAUTION!

Important notice to be observed.

1 TECHNICAL SPECIFICATION OF PRODUCT

1.1 FUNCTION DESCRIPTION

After the heater is connected to electric network, the heating element starts heating water. The element is turned on and off by a thermostat.

Thermostat can be set as per your need within the range from 7°C to 74°C. We recommend setting service water to max temperature of 60°C. This temperature ensures the optimal operation of the heater. After reaching the temperature set, the thermostat switches off the electric circuit and thus discontinues water heating. The control light signals if the element is in operation (light is on) or if it is off (the light goes out). In case of longer operation without using the heated volume the thermostat has to be set to position 5°C to 12°C (set the “snowflake” symbol on the thermostat selector) to avoid its freezing.

1.2 ADVICE FOR CUSTOMERS

1.2.1 HOT WATER CONSUMPTION



Consumption of hot water in households depends on the number of people, amount of sanitary equipment, length, diameter and insulation of piping in the flat, or on individual habits of users. The cheapest option of water heating comes at the time when the electricity rate is reduced.



Find out in what time intervals your electricity supplier provides reduced tariff and, depending on that information, select relevant volume and power input of the heater so that your hot water consumption covered the needs of your household.

1.2.2 ENERGY SAVING



Adjust the temperature of the heater's thermostat to that level only that you need to run your home. Thus you will reduce electricity consumption, as well as the amount of lime sediments on the walls of the receptacle and on the electric element's pit.

1.2.3 EMERGENCY POWER CONSUMPTION



If no heated water is taken from the tank, a small amount of heat leaks. This loss is measured for a period of 24 hours at the temperature of 65°C in the heater, and at 20°C in its ambient area. The resulting value is expressed in [kWh/24h] and indicates the amount of power needed to maintain the set temperature. Its benefit is that it heats up water by power in an unlimited all-day time range. The time of heating service water to the recommended temperature of 60°C is about 31 minutes. With its design, the electric accumulation heater TO - 20 is suitable for installations in bathrooms, lavatories, kitchens or near sanitary units of panel flats, and complies with the requirements of Standards, with the IP 44 protection class. Data Sheet pursuant to Directive No to see in Table 1.

TYPE	TO - 20
UNIT HEAT LOSS [Wh/24h/l]	14
NOMINAL CAPACITY [l]	20
TIME OF CONTENT HEATING BY 50°C [hours]	0.5
ELECTRICITY CONSUMPTION FOR HEATING OF THE CONTENTS FROM	1
LOAD PROFILE	S
DAILY ELECTRICITY CONSUMPTION [kWh]	2.24
MIXED WATER V40 [l]	26.92

Table 1

1.3 DESIGN AND GENERAL HEATER DIMENSIONS

The heater tank is made of a steel plate and tested by 0.9 MPa overpressure. The inner surface of the tank is provided (except the stainless coil) with anticorrosion protection of enamelled glaze.

In the bottom part of the tank there are wells for placing the heating, regulation and safety element of the water heater (heating element with right thread G 5/4", thermostat sensor and thermal fuses). A thermometer is installed in the top part of the heater that transmits information on heating the volume of service water. The heater tank is provided with a highly valuable polyurethane insulation which ensures minimum heat losses.

Electric wiring is placed in the bottom part of the heater, under an easily removable guard of the heater (by loosening two screws on that guard). Temperature of water can be set by a thermostat within the range between 0°C and 74°C, using the symbols on the thermostat selector button Figure 1. Cold water inflow is indicated with a blue ring, hot water outflow is indicated with a red ring. All steel parts are protected against corrosion with paint and galvanic coating. To ensure anticorrosion protection, the heating element head is provided with an anode rod that dissolves when the heater is in operation, and has to be replaced after 3 years of operation (depending on the aggressiveness of water).

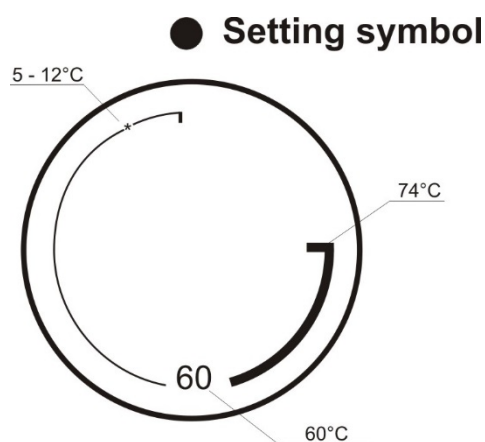

Figure 1

2 OPERATION AND FITTING INSTRUCTIONS

2.1 OPERATING CONDITIONS



The tank shall only be used in accordance with the conditions specified on the performance plate and in instructions for electric wiring. Besides legally acknowledged national regulations and standards, also conditions for connection defined in local electric and water works have to be adhered to, as well as the installation and operation manual. It is recommended to use the product in an indoor environment with air temperatures from +2°C to 45°C and maximum relative humidity of 80%. The room, in which the appliance will be operated, must be frost-free. The appliance has to be mounted at a convenient place, it means that the appliance must be easily available for potential necessary maintenance, repair or replacement, as the case may be. Parameters are in Table 2.



If water is strongly calcareous we recommend that any of the common decalcifying devices was installed with the appliance, or the thermostat to be set to minimum operation temperature of 60°C. For proper operation, drinkable water of adequate quality shall be used. To avoid potential sediments we recommend that the device was installed together with a water filter.

2.2 WALL MOUNTING



Prior to the mounting, check the bearing capacity of the wall and the material it is made of, considering the weight of the heater filled with water. Depending on the wall material, choose adequate fixtures. Should you have any doubts regarding the wall bearing capacity, consult the suspension with a building specialist. The minimum diameter of the bolts for suspending the heater is **12 mm**. **When mounting the anchor bolts follow the guide provided by the anchor bolts' manufacturer.**

Mount the anchors by the dimensional drawing on Figure 2 in **180 mm** spacing, and screw firmly a steel hinge onto the wall. Check its proper vertical positioning. Double check the torque of the suspension bolts on the heater and suspend the heater. If needed, the suspension bolts can be shifted by **50 mm** in vertical direction. Using the detent support in the bottom part of the heater make sure it runs in parallel with the wall!

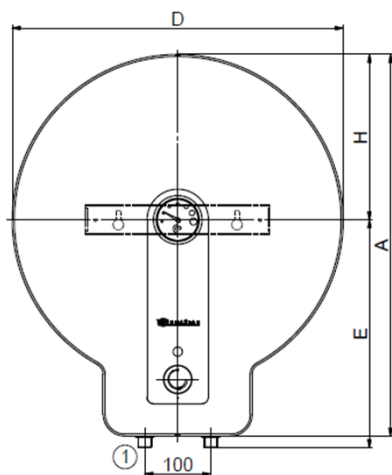
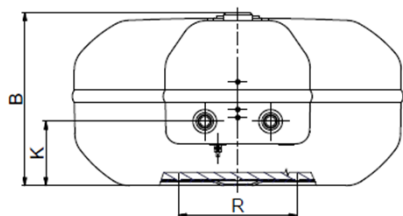

TO 20	
A	579
B	266
D	502
E	346
H	251
K	98
R	180

①	1/2" outer
---	------------

Figure 2

PARAMETER	VALUE
RATED PRESSURE [MPa]	0.6
CAPACITY [l]	20
VOLTAGE/FREQUENCY [V/Hz]	230/50
POWER INPUT [W]	2200
DIAMETER OF THE HEATER [mm]	502
HEIGHT OF THE HEATER [mm]	597
WEIGHT [kg]	12
EL. PROTECTION	IP 44
HEAT LOSSES/ENERGY EFFICIENCY CLASS [kWh/24h]	0.28
TIME OF EL. HEATING FROM 10°C TO 60°C	31

Table 2



If the hot water heater is mounted in a **tight, small space**, or in an intermediate ceiling, etc., you have to make sure that the connecting side of the appliance (connections to water supply, area for electric plugging) remained accessible and no heat accumulation occurs. Free space of up to **600 mm** from the bottom edge of the heater has to be available under the heater. When mounted directly under the ceiling, the distance from the ceiling has to be **50 mm** at least.

2.3 PLUMBING FIXTURE



Connection to plumbing fixtures is illustrated on Figure 3. For potential disconnection of the heater, the service water inlets and outlets must be provided with screw coupling G1/2". The safety valve can be mounted both in vertical and horizontal position in the indicated direction of cold water flow. Safety valve is mounted on the cold water inlet identified with a blue ring. The heaters must be equipped with a drain valve.



Each hot service water pressure heater must have a safety valve with a membrane spring. The safety valve must be easily accessible, as close to the heater as possible. The input pipes must have at least the same clearance as the safety valve. The safety valve is placed high enough to secure dripping water drain by gravity. We recommend mounting the safety valve onto a branch pipe. This allows easier exchange without having to drain the water from the heater. Safety valves with fixed pressure settings from the manufacturer are used for the assembly. Starting pressure of a safety valve must be identical to the maximum allowed heater pressure, and at least 20% higher than the maximum pressure in the water main. If the water main pressure exceeds such value, a reduction valve must be added to the system. No stop valves can be put between the heater and the safety valve. During the assembly, follow the guide provided by the safety equipment manufacturer. It is necessary to check the safety valve each time before putting it into operation. It is checked by manual moving of the membrane from the seat, turning the make-and-break device button always to the right. After being turned, the button must click back into a notch. Proper function of the make-and-break device results in water draining through the safety valve outlet pipe. The cold water inlet of each individually closable heater must be fitted with a seal, test tap or plug to check the non-return valve, as well as a non-return valve and safety valve. Heaters with a volume of more than 200 litres must also be fitted with a pressure gauge.



Water may be dripping off the drain pipe of the safety valve; the pipe must be open into the air, pointed down; environment temperatures must not drop below zero. When draining the heater, use a recommended drain valve. First, close water input into the heater. Find necessary pressure values in the following Table 3. For proper safety valve operation, a backflow valve must be mounted on the inlet pipes, preventing spontaneous heater draining and hot water penetrating back into the water main. When assembling the security equipment, follow Standards. We recommend that the hot water distribution from the heater was as short as possible to minimise heat losses.

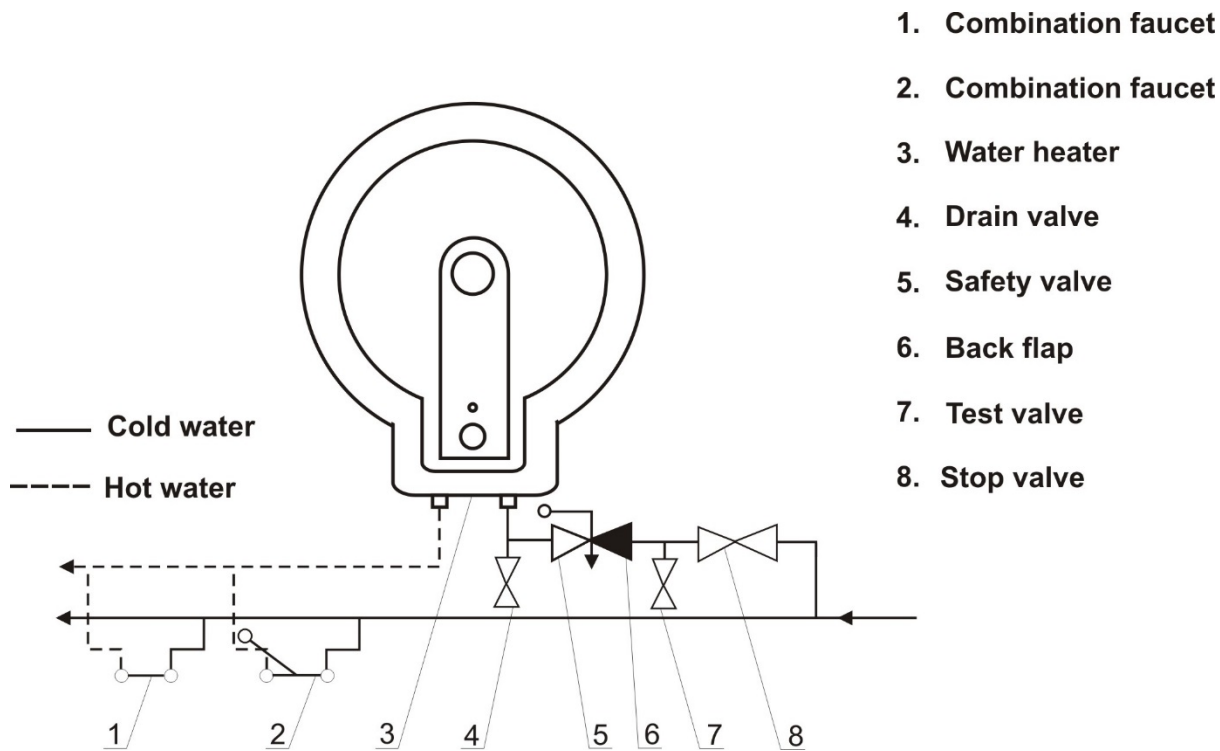

Figure 3

SAFETY VALVE STARTING PRESSURE [MPa]	ADMISSIBLE OPERATING WATER HEATER PRESSURE [MPa]	MAX. PRESSURE IN THE COLD WATER PIPE [MPa]
0.6	0.6	to 0.48
0.7	0.7	to 0.546
1	1	to 0.8

Table 3

Heaters must be provided with a discharge valve mounted on the cold service water inlet to the heater for potential disassembly or repair. When assembling the security equipment, follow Standards.

2.4 ELECTRIC WIRING

2.4.1 ELECTRIC INSTALLATION GENERAL INFORMATION

The electric wiring scheme is attached to the water heater on the inner side of the removable front guard (Figure 4). The degree of protection of electric parts of the heater is IP 44. Power input of electric element is 2200 W.

It is necessary to observe the below requirements during the electric wiring.



- The heater is connected to the 230V/50Hz electric network using a fixed moving conductor with a switch that turns off all network poles and the circuit breaker (protector).
- Connection, repairs, and wiring inspections may only be implemented by a company (person) authorised to such activity. Expert connection must be confirmed on the warranty certificate
- The circuit must contain a breaker disconnecting all poles of the network, and a circuit breaker (protector).
- In order to enhance the protection of connection in bathrooms and shower inserts pursuant to Standard, the appliance is provided with a grounding terminal for connecting with a yellow-green protective conductor on minimum section 4 mm².
- To adjust the distance from the wall, connect the wire of the external protective bonding!
- Respect the rules of protection against electrical injuries in accordance with Standards.
- Access to the electric part of the heater is enabled only upon disconnecting the heater from power supply and unscrewing the guard of the heater.

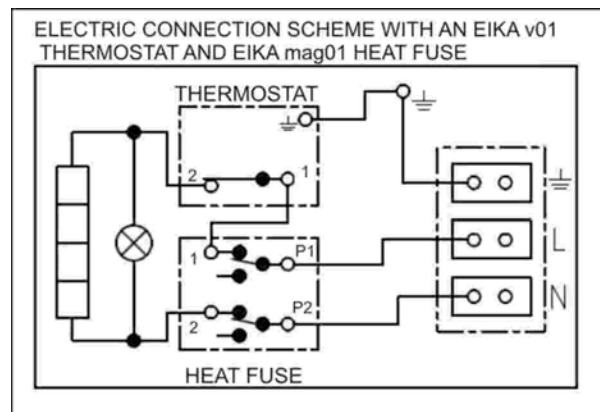

Figure 4

2.5 FIRST HEATER COMMISSIONING



Before opening the power supply, the tank must be filled with water. The process of first heating must be executed by licensed professional who has to check it. Both the hot water outlet pipe and safety armature parts may be hot.



During the heating process the pressurised connection water that increases its volume due to heating must drip off the safety valve. In non-pressurised connection water drips off the overflow combination faucet. When heating is finished, the set temperature and the actual temperature of consumed water should be roughly equal. After connecting the heater to the water main and electrical power system, and after checking the safety valve (following the instructions attached to the valve), the heater can be put into operation.

The product is attached with a safety valve, 2 spiral dives 6x70 and 2 plastic wall plugs 12x60. The above parts are packed and placed in the packaging together with the heater. It is in your own interest to check the completeness of the accessories.

Procedure of putting the heater into operation:

1. Check the wiring and water supply; check correct position of the thermostat sensors, they have to be inserted all the way. The sensors must be inserted all the way in; first the operating and then the safety thermostat.
2. Open the hot water valve on the combination faucet.
3. Open the cold water inlet valve to the heater.
4. As soon as the water starts running through the hot water valve, the heater is filled and the valve can be closed.
5. Prior to putting the heater into operation, screw on the front heater guard which closes the access to the electric compartment of the heater.
6. In case of a leakage (flange lid), we recommend fastening the flange lid bolts.
7. Screw down the electric installation guard.
8. When hot service water heating by electric energy, switch on the power supply.
9. When commencing operation, flush the heater until the cloudiness in the water is gone.
10. Make sure to fill in properly the warranty certificate.

2.6 PUTTING OUT OF SERVICE, DISCHARGE



If the hot water heater is put out of service for a longer time, or if it is not going to be used it has to be drained and disconnected from the electric supply network on all poles. The switch for the supply lead or the fuse cut-outs have to be shut off.

At places with permanent risk of frost the hot water heater must be drained before the cold season starts if the appliance remains out of service for several days and if the power supply is disconnected.



Drainage of service water shall be performed after closing the shut-off valve in the cold water supply piping (through the discharge valve for safety valve combination), and with simultaneous opening of all hot water valves of connected fittings. **Hot water may outflow during the drainage!** If there is a risk of frost it has to be considered that not only the water in the hot water heater and in the hot water piping may get frozen but also the water in the entire cold water supply piping. It is therefore advisable to drain all fittings and piping that carry water, up to the part where the house water meter is installed (connection of the house to water main) which is not jeopardised by frost. When the tank is to be used again, it has to be filled with water and one needs to make sure that the water **flowing out at the hot water valves did not contain any bubbles.**

2.7 INSPECTION, MAINTENANCE & CARE FOR THE APPLIANCE



During the heating process the water that increases its volume during the heating must drip off the safety valve outlet (in non-pressurised connection this water drips off the combination faucet valve). In full heating (about 65°C) the volumetric water gain is approx. 3% of the tank capacity. The function of the safety valve has to be checked regularly (based on the information contained in the attached safety valve manual). In common operation, such a check needs to be implemented at least once a month, and after each heater shutdown that exceeds 5 days.

Caution! In doing so, the cold water supply pipe and the connection fitting of the tank may get heated! If the hot water heater does not work, or if hot water is not withdrawn, no water shall drip off the safety valve. If water drips, then the pressure in the supply piping is either too high, or the safety valve is defective. Please call a specialised plumber immediately!



If water contains too many minerals, an expert has to come to remove the scale that forms inside the tank, as well as free sediments. This has to be performed after one or two years of operation. The cleaning is carried out through the hole in the flange by: draining the boiler, dismantling the flange lid and cleaning the tank. A new sealing has to be used for re-fitting. Since the inside of the heater has special enamel, the surface of which must not get in contact with a scale removing agent - do not work with a lime pump. Remove the lime layer with a timber and suck it off, or wipe it off with a clout. After that, the appliance must be rinsed thoroughly and the heating process is checked the same as during the initial putting in operation. Do not use any abrasive cleaning agents or dye thinners to clean the outer shell of the heater (such as cellulose thinner, trichlor, and the like). For cleaning use a wet clout and add a few drops of liquid cleaning agent for household applications.

Repetitive water heating causes limestone sediment on both the enamelled tank walls and chiefly the flange lid. The sedimentation depends on the hardness of water heated, its temperature, and amount of hot water consumed.

We recommend checking and cleaning the tank from scale and eventual replacement of the anode rod after two years of operation. The anode life is theoretically calculated for two years of operation; however, it changes with water hardness and chemical composition in the place of use. Based on such an inspection, the next term of anode rod exchange may be determined. Have the company in charge of service affairs clean and exchange the anode. When draining water from the heater, the combination faucet valve for hot water must be open, preventing occurrence of under-pressure in the heater tank which would stop the water from draining.

2.8 MOST FREQUENT FUNCTION FAILURES AND THEIR CAUSES

FAILURE SYMPTOM	LED	SOLUTION
Water in tank is cold	<ul style="list-style-type: none"> • LED is on 	<ul style="list-style-type: none"> • Heating element failure
Water in the tank is not warm enough	<ul style="list-style-type: none"> • LED is on 	<ul style="list-style-type: none"> • Heating element failure
Water in the tank is cold	<ul style="list-style-type: none"> • LED is not on 	<ul style="list-style-type: none"> • Thermostat failure - the safety fuse turned off electricity supply • Power supply outside the heater discontinued
Water in the tank does not correspond with temperature set	<ul style="list-style-type: none"> • LED is on 	<ul style="list-style-type: none"> • thermostat failure

Table 4



Do not try to repair the failure yourselves. Seek either expert or service help. It does not take much for an expert to remove the defect. When making a repair appointment, report the type and serial number you find on the performance plate of your water heater.

3 IMPORTANT NOTICES

3.1 INSTALLATION REGULATIONS

- Without a confirmation of performed electrical and plumbing fixture issued by an authorised company the warranty certificate shall be void.
- You have to apply for approval of a local power supplier to connect the heater.
- All hot water outlets must be provided with a combination faucet.
- It is not allowed to handle the thermostat in any manner whatsoever, aside from temperature resetting with a control button.
- All electric installation handling, setting, and regulation feature exchange, may only be implemented by an authorised service company.
- The thermal fuse must not be turned off. In case of thermostat defect, the thermal fuse interrupts electric power input to the heating element if the water temperature in the heater exceeds 99°C.



Both the electric and water installation must follow and meet the requirements and regulations relevant in the country of use!

We would like to emphasise that the heater must not be connected to power supply if work involving flammable liquids (petrol, spot remover) or gases, etc., is performed nearby.

3.2 DISPOSAL OF PACKAGING MATERIAL AND FUNCTIONLESS PRODUCT

A service fee for providing return and recovery of packaging material has been paid for the packaging in which the water heater was delivered. The service fee was paid pursuant to Act No 477/2001 Coll., as amended, at EKO-KOM a.s. The client number of the company is F06020274. Take the water boiler packages to a waste disposal place determined by the town. When the operation terminates, disassemble and transport the discarded and unserviceable heater to a waste recycling centre (collecting yard), or contact the manufacturer.



4 PRODUCT ACCESSORIES

- Safety valve G1/2"
- Screws 6 x70mm – 2 pcs
- Plastic dowels 12x60mm – 2 pcs
- Manual on CD

It is in your own interest to check the completeness of the accessories.

19-4-2017