

STORAGE TANKS



ESDRAŽICE



IT ALL BEGAN WITH A SIMPLE IDEA

to produce the most cost-efficient and trouble-free water heater – the best storage heater. Every year, we think we are close enough to our goal. And yet, every year we produce more sophisticated water heaters, storage tanks and heating elements, ...

Maximum user comfort, energy efficiency and environmental responsibility are the main driving forces in our daily work.



STORAGE TANKS /RESERVOIRS/ without DHW preparation	8	STORAGE TANK NAD v1
	10	STORAGE TANK NAD v2
	11	STORAGE TANK NAD v3
	12	STORAGE TANK NADS v3
	13	STORAGE TANK NAD v4
	14	STORAGE TANK NAD v5
	15	STORAGE TANK UKV
<hr/>		
STORAGE TANKS /RESERVOIRS/ with DHW preparation	18	STORAGE TANK NADO v1
	22	STORAGE TANK NADOS v1
	24	STORAGE TANK NADO v2
	26	STORAGE TANK NADOS v2
	28	STORAGE TANK NADO v3
	30	STORAGE TANK NADO v6
	32	STORAGE TANK NADO v7
	34	STORAGE TANK NADO v9
36	STORAGE TANK NADO v11	
<hr/>		
ACCESSORIES	40	HEAT INSULATION NEODUL LB PP
	41	IPS PROTECTX AND PROTECT CH
	42	ORIGINAL PARTS FROM DRAŽICE
	44	ACCESSORY TABLES
<hr/>		
ANOTHER ASSORTMENT	48	PHOTOVOLTAIC
	49	WATER HEATERS
	50	AIR CONDITION - SPLIT AND MULTISPLIT

Tolerance of all stated dimensions complies with ČSN ISO
Z/T circuit socket = socket of heating sources and heating circuits
Note: * The value is derived by calculation

STORAGE TANKS

serve to accumulate excess heat from its source. The source may be a solid fuel boiler, heat pump, solar collectors, a fireplace insert etc. Some types of tanks allow combining and connecting multiple sources of heat.



NAD, NADS a UKV storage tanks (without DHW preparation) serve only for storing heat in the heating system.



NADO a NADOS storage tanks (with DHW preparation) also allow indirect water heating or water preheating for another water heater.

Legend to

ICONS

INLETS



Solid fuel boiler



Biomass boiler



Fireplace insert



Electric heating
– dry ceramic unit TPK 210–12



Electric heating
– wet unit TJ 6/4"



Heat pump



Photothermic solar system



Photovoltaic solar system

OUTLETS



Floor heating



Radiator



Hot water







STORAGE TANKS

WITHOUT DHW PREPARATION

NAD v1 /types 50, 100 and 250/

STORAGE TANK

WITHOUT DHW PREPARATION



- Types: 50, 100, 250
- The tank is supplied with non-detachable insulation
- Suitable as an equalization tank for heating systems with solid fuel boilers
- Also suitable for cooling
- The TJ 6/4" heating unit can be mounted into the socket



NAD 50 v1, 100v1



NAD 250 v1

Socket dimensions	NAD 50 v1	NAD 100 v1	NAD 250 v1
Socket 1	1" female thread		1" female thread
Socket 2	1 1/2" female thread		1/2" female thread
Socket 3	1/2" female thread		1" male thread
Socket 4	-		1 1/2" female thread

Technical parameters		NAD 50 v1	NAD 100 v1	NAD 250 v1
Order number		110580391	1108803102	1109803191
Heating water volume in tank	[l]	50	120	265
Weight (Netto)	[kg]	25	41	63
Max. operating temperature / pressure in tank	[°C] / [bar]	90 / 3		
Insulation thickness (Polyurethane)	[mm]	42		
Heat conductivity of insulation (Polyurethane)	[W·m ⁻¹ ·K ⁻¹]	0,022		
Insulation order number (Polyurethane)		tank component		
Max. number × output of TJ 6/4"	[pcs] × [kW]	1 × 3,3	1 × 6	
Energy efficiency class (Polyurethane)		B		C
Standing loss (Polyurethane)	[W]	31	41	88

Tank dimensions		NAD 50 v1	NAD 100 v1	NAD 250 v1
Tank diameter with insulation	∅ D	524	584	584
Tank diameter	∅ d	440	500	500
Total tank height	L	561	803	1568
Tilting height	L _t	-	-	1605
Tank height	H	-	-	1535
Discharging connection	A	215	225	225
Z/T circuit socket	B	345	575	1305
TJ 6/4" heating unit socket	C	265	400	825
Sensor pocket socket	E	365	555	950
Spacing of user-type suspension	R	300-310, 350-372, 432-468		-

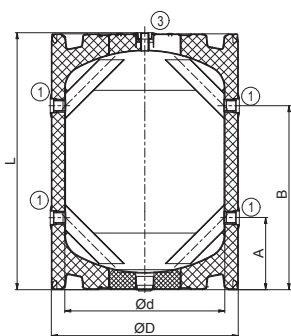

NAD 50, 100 v1

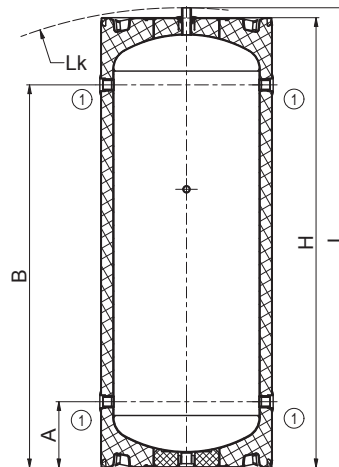
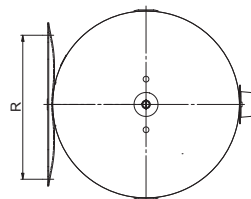

NAD 250 v1

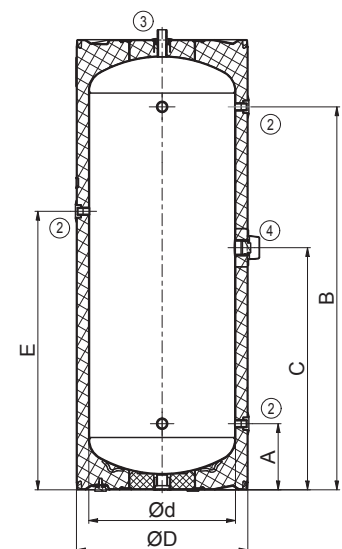

NAD v1 /types 500–2000/

STORAGE TANK

WITHOUT DHW PREPARATION



- Types: 500, 750, 1000, 1500, 2000 l
- The tank is supplied without insulation
- Modern Neodul insulation can be ordered
- Suitable as an equalization tank for heating systems with solid fuel boilers
- The TPK 210-12 heating unit can be mounted into the flange
- We can supply 2 more custom made flanges for the tank
- The TJ 6/4" heating unit can be mounted into the socket

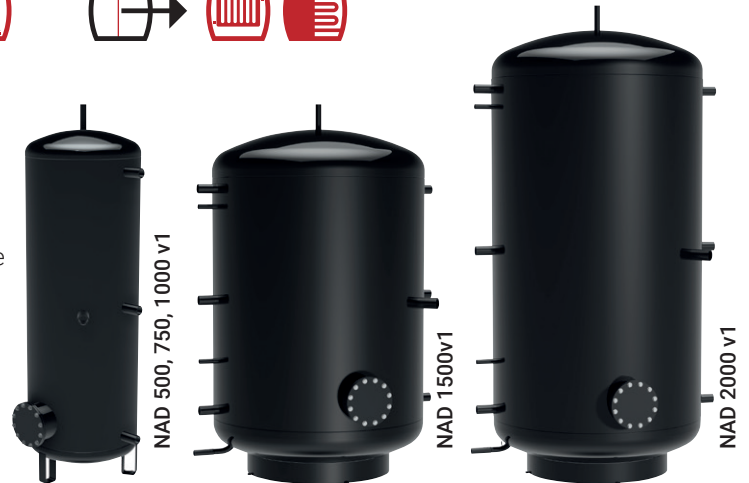

Socket dimensions	NAD 500 v1	NAD 750 v1	NAD 1000 v1	NAD 1500 v1	NAD 2000 v1
Socket 1 – female thread			1 ¼"		
Socket 2 – female thread			½"		
Socket 3 – male thread			1"		
Socket 4 – female thread			1 ½"		

Technical parameters		NAD 500 v1	NAD 750 v1	NAD 1000 v1	NAD 1500 v1	NAD 2000 v1
Order number		121380393	121680393	121580393	122180393	122280393
Heating water volume in tank	[l]	475	772	999	1507	2007
Weight (Netto)	[kg]	85	109	126	204	247
Max. operating temperature / pressure in tank	[°C] / [bar]	90 / 3				
Insulation thickness (Neodul LB PP)	[mm]	80			100	120
Heat conductivity of insulation (Neodul LB PP)	[W·m ⁻¹ ·K ⁻¹]	0,032				
Insulation order number (Neodul LB PP)		6231902	6231904	6231905	6231710	6231711
Max. number × output of TPK 210-12	[pcs] × [kW]	1 × 12				
Max. number × output of TJ 6/4"	[pcs] × [kW]	1 × 9				
Energy efficiency class (Neodul LB PP)		C				
Standing loss (Neodul LB PP)	[W]	83	122	135	165	185

Tank dimensions		NAD 500 v1	NAD 750 v1	NAD 1000 v1	NAD 1500 v1	NAD 2000 v1
Tank diameter	∅ d	600	750	850	1100	1100
Total tank height	L	1970	2030	2040	1906	2436
Tilting height	L _k	1990	2050	2060	1925	2480
Tilting height	H	1847	1903	1916	1778	2307
Discharging connection	A	100	100	100	135	135
Z/T circuit socket	B	270	282	297	350	350
Z/T circuit socket	C	958	970	985	910	1175
Z/T circuit socket	E	1644	1656	1671	1470	2000
Sensor pocket socket	F	505	517	532	600	600
Sensor pocket socket	G	1554	1566	1581	1380	1910
TJ 6/4" heating unit socket	I	937	950	965	895	1160
Flange socket	J	353	366	381	450	450

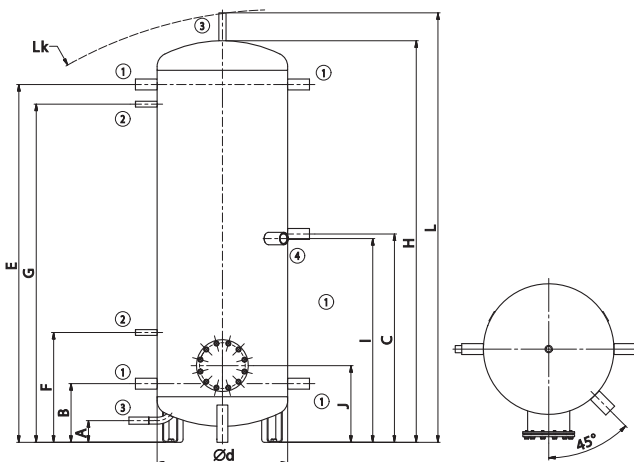

NAD 500, 750, 1000 v1

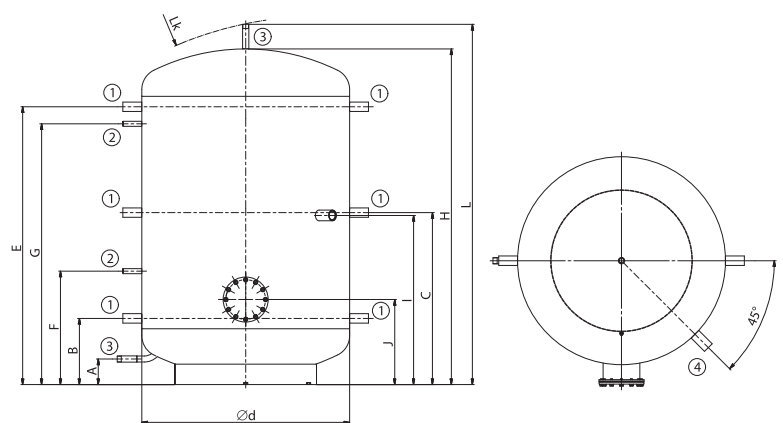

NAD 1500, 2000 v1

NAD v2

STORAGE TANK

WITHOUT DHW PREPARATION



- Types: 500, 750, 1000, 1500, 2000 l
- The tank is supplied without insulation
- Modern Neodul insulation can be ordered
- Suitable as an equalization tank for heating systems with solid fuel boilers
- The TJ 6/4" heating unit can be mounted into the socket



Socket dimensions	NAD 500 v2	NAD 750 v2	NAD 1000 v2	NAD 1500 v2	NAD 2000 v2
Socket 1 - female thread			1 ¼"		
Socket 2 - female thread			½"		
Socket 3 - male thread			1"		
Socket 4 - female thread			1 ½"		

Technical parameters		NAD 500 v2	NAD 750 v2	NAD 1000 v2	NAD 1500 v2	NAD 2000 v2
Order number		121380394	121680394	121580394	122180394	122280394
Heating water volume in tank	[l]	475	772	999	1507	2007
Weight (Netto)	[kg]	76	101	114	192	235
Max. operating temperature / pressure in tank	[°C] / [bar]	90 / 3				
Insulation thickness (Neodul LB PP)	[mm]	80			100	120
Heat conductivity of insulation (Neodul LB PP)	[W·m ⁻¹ ·K ⁻¹]	0,032				
Insulation order number (Neodul LB PP)		6231908	6231913	6231909	6231712	6231713
Max. number x output of TJ 6/4"	[pcs] x [kW]	1 x 9				
Energy efficiency class (Neodul LB PP)		C				
Standing loss (Neodul LB PP)	[W]	83	122	135	165	185

Tank dimensions		NAD 500 v2	NAD 750 v2	NAD 1000 v2	NAD 1500 v2	NAD 2000 v2
Tank diameter	∅ d	600	750	850	1100	1100
Total tank height	L	1970	2030	2040	1906	2436
Tilting height	L _k	1990	2050	2060	1925	2480
Tank height	H	1847	1903	1916	1778	2307
Discharging connection	A	100	100	100	135	135
Z/T circuit socket	B	270	282	297	365	365
Z/T circuit socket	C	1644	1656	1671	1470	2000
Sensor pocket socket	E	505	517	532	600	600
Sensor pocket socket	F	1554	1566	1581	1380	1910
TJ 6/4" heating unit socket	G	375	386	402	470	470

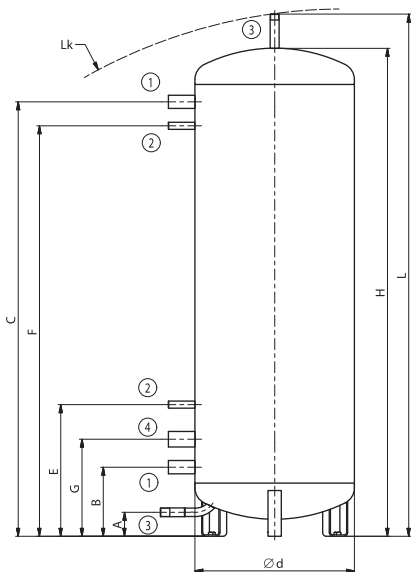

NAD 500, 750, 1000 v2

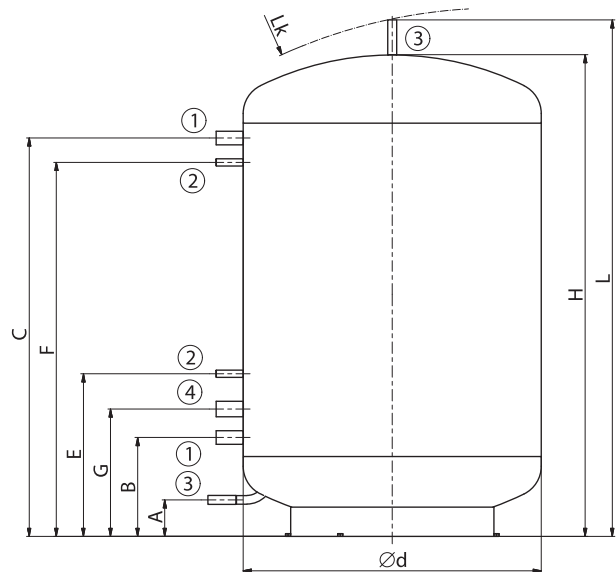

NAD 1500, 2000 v2

NAD v3

STORAGE TANK

WITHOUT DHW PREPARATION



- Types: 300, 500, 750, 1000 l
- The tank is supplied without insulation
- Modern Neodul insulation can be ordered
- Suitable as an equalization tank for heating systems with solid fuel boilers
- The TPK 210-12 heating unit can be mounted into the flange
- The TJ 6/4" heating unit can be mounted into the socket

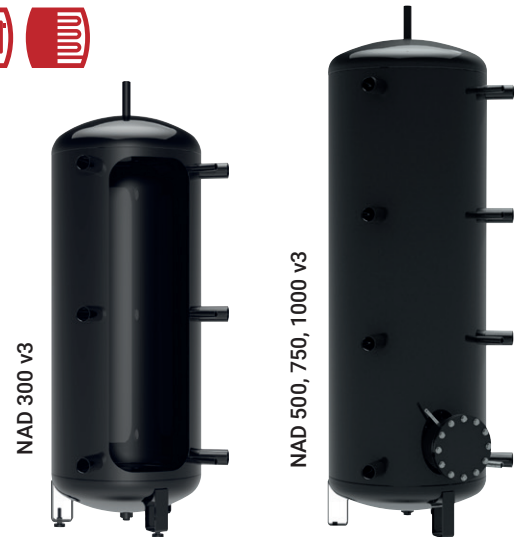

Socket dimensions	NAD 300 v3	NAD 500 v3	NAD 750 v3	NAD 1000 v3
Socket 1 - female thread		1 1/2"		
Socket 2 - female thread		1/2"		
Socket 3 - female thread		1"		

Technical parameters		NAD 300 v3	NAD 500 v3	NAD 750 v3	NAD 1000 v3
Order number		121080387	121380387	121680387	121580387
Heating water volume in tank	[l]	320	475	772	999
Weight (Netto)	[kg]	60	87	110	126
Max. operating temperature / pressure in tank	[°C] / [bar]	90 / 3			
Insulation thickness (Neodul LB PP)	[mm]	80			
Heat conductivity of insulation (Neodul LB PP)	[W·m ⁻¹ ·K ⁻¹]	0,032			
Insulation order number (Neodul LB PP)		6231900	6231912	6231906	6231910
Max. number × output of TPK 210-12	[pcs] × [kW]	1 × 12			
Max. number × output of TJ 6/4"	[pcs] × [kW]	1 × 3,3+3×9	2 × 3,3+4×9	2 × 3,75+4×9	2×6+4×9
Energy efficiency class (Neodul LB PP)		C			
Standing loss (Neodul LB PP)	[W]	80	83	122	135

Tank dimensions		NAD 300 v3	NAD 500 v3	NAD 750 v3	NAD 1000 v3
Tank diameter	∅ d	550	600	750	850
Total tank height	L	1610	1970	2030	2040
Tilting height	L _k	1620	1990	2050	2060
Tank height	H	1480	1847	1903	1916
Z/T circuit and sensor pocket socket	A	245	270	282	297
Z/T circuit and sensor pocket socket	B	760	728	739	755
Z/T circuit and sensor pocket socket	C	1275	1186	1197	1213
Z/T circuit and sensor pocket socket	E	-	1644	1656	1671
Flange socket	F	-	353	366	381

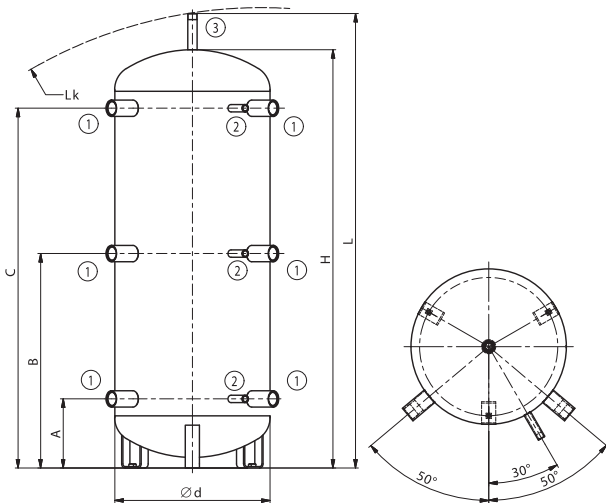

NAD 300 v3

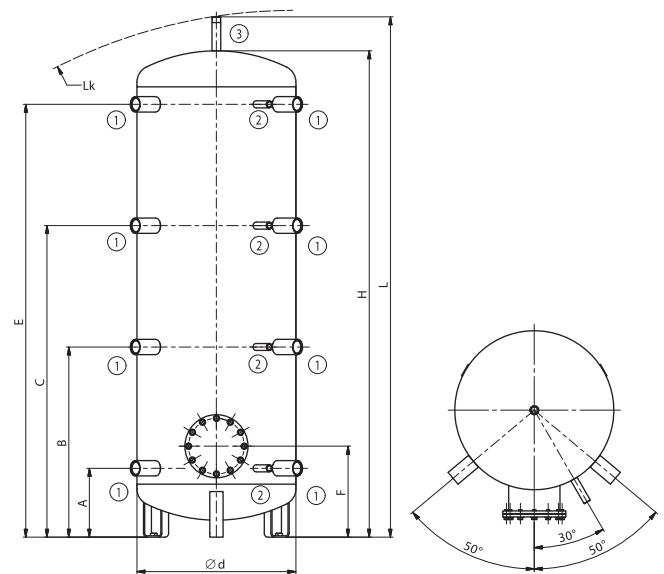

NAD 500, 750, 1000 v3

NADS v3

STORAGE TANK

WITHOUT DHW PREPARATION



- Types: 800, 900 l
- The tank is supplied without insulation
- Modern Neodul insulation can be ordered
- Suitable as an equalization tank for heating systems with solid fuel boilers
- The TJ 6/4" heating unit can be mounted into the socket
- The tank is dimensioned for passage through the 80 cm door



Socket dimensions	NADS 800 v3	NADS 900 v3
Socket 1 – female thread	1 1/2"	
Socket 2 – female thread	1/2"	
Socket 3 – male thread	1"	
Socket 4 – female thread	1"	

Technical parameters		NADS 800 v3	NADS 900 v3
Order number		121880387	121880388
Heating water volume in tank	[l]	775	930
Weight (Netto)	[kg]	100	132
Max. operating temperature / pressure in tank	[°C] / [bar]		90 / 3
Insulation thickness (Neodul LB PP)	[mm]		80
Heat conductivity of insulation (Neodul LB PP)	[W·m ⁻¹ ·K ⁻¹]		0,032
Insulation order number (Neodul LB PP)		6232097	6232098
Max. number × output of TJ 6/4"	[pcs] × [kW]		1 × 3,75+3×9
Energy efficiency class (Neodul LB PP)		C	
Standing loss (Neodul LB PP)	[W]	116	132

Tank dimensions		NADS 800 v3	NADS 900 v3
Tank diameter	∅ d	790	790
Total tank height	L	1880	2205
Tilting height	L _x	1900	2220
Tank height	H	1750	2075
Discharging connection	A	157	157
Z/T circuit socket	B	275	275
Z/T circuit socket	C	870	1020
Z/T circuit socket	E	1470	1795
Sensor pocket	F	365	365
Sensor pocket	G	1380	1705

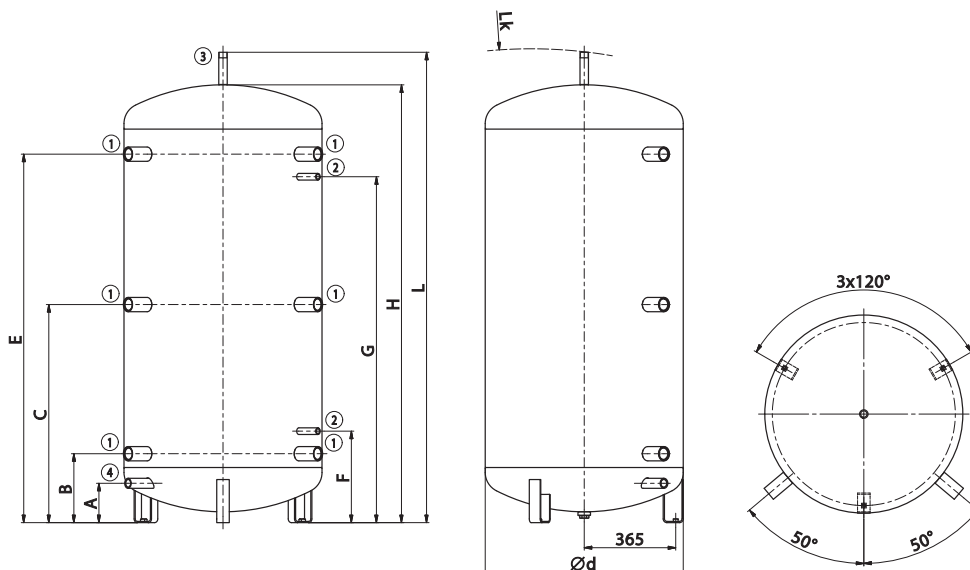

UKV

STORAGE TANK

WITHOUT DHW PREPARATION



- Types: 300 a 500 l
- The tank is supplied with non-detachable insulation
- Suitable as a storage tank for heating systems with heat pumps
- Also suitable for cooling
- The TJ 6/4" heating unit can be mounted into the socket



Socket dimensions	UKV 300	UKV 500
Socket 1	1 ¼" female thread	1 ½" female thread
Socket 2	1 ½" male thread	1" male thread
Socket 3	½" female thread	½" female thread
Socket 4	1" male thread	-

Technical parameters		UKV 300	UKV 500
Order number		1210803171	1213803137
Heating water volume in tank	[l]	316	470
Weight	[kg]	79	103
Max. operating temperature / pressure in tank	[°C] / [bar]		90 / 6
Insulation thickness (Polyurethane)	[mm]		50
Heat conductivity of insulation (Polyurethane)	[W·m ⁻¹ ·K ⁻¹]		0,022
Max. number × output of TJ 6/4"	[pcs] × [kW]	2 × 7,5	2 × 9
Energy efficiency class (Polyurethane)		C	C
Standing loss (Polyurethane)	[W]	79	96

Tank dimensions		UKV 300	UKV 500
Tank diameter	∅ d	550	600
Tank diameter with insulation	∅ D	650	700
Total tank height	L	1580	1937
Tilting height	L _k	1610	1980
Z/T circuit socket	A	230	270
Z/T circuit socket	B	1300	1400
Z/T circuit socket	C	-	1650
Heating unit socket	E	1030	1400
Heating unit socket	F	1180	1550
Sensor pocket socket	G	230	270
Sensor pocket socket	I	766	960
Sensor pocket socket	J	1300	1650

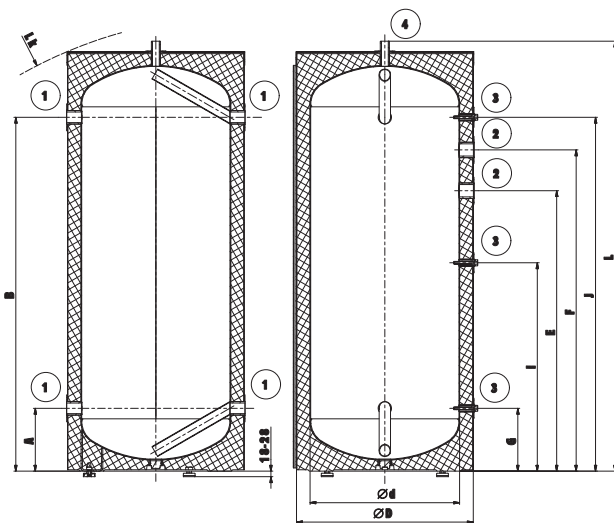

UKV 300

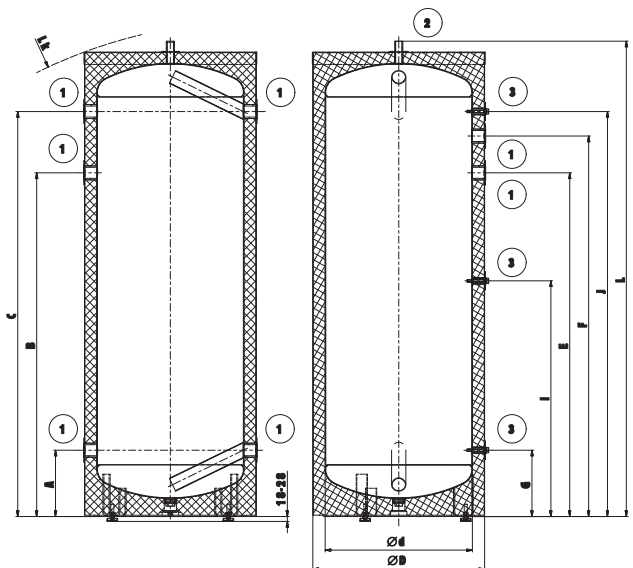

UKV 500





STORAGE TANKS

WITH DHW PREPARATION

NADO v1

STORAGE TANK

WITH DHW PREPARATION



- Types: 500, 750, 1000 l
- Inner HW storage tank in volumes of 140 and 200 l
- The tank is supplied without insulation
- Modern Neodul insulation can be ordered
- Suitable as a storage tank for heating systems with solid fuel boilers
- The TPK 210-12 heating unit can be mounted into the flange
- The TJ 6/4" heating unit can be mounted into the socket for 140 l version

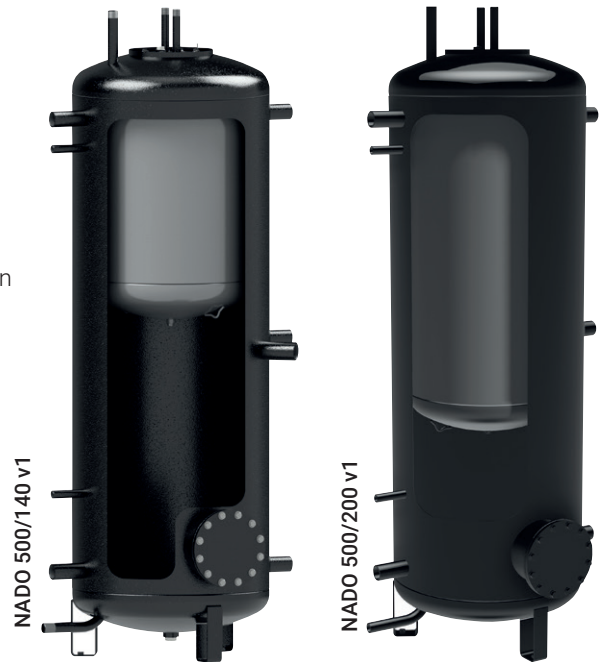

Socket dimensions	NADO 500 v1	NADO 750 v1	NADO 1000 v1
Socket 1 – female thread		1 ¼"	
Socket 2 – female thread		½"	
Socket 3 – male thread		1"	
Socket 4 – male thread		¾"	
Socket 5 – female thread		1 ½"	

Technical parameters		NADO 500/140 v1	NADO 750/140 v1	NADO 1000/140 v1	NADO 500/200 v1	NADO 750/200 v1	NADO 1000/200 v1
Order number		121380315	121680315	121580315	121380397	121680397	121580397
Heating water volume in tank	[l]	475	772	999	475	772	999
Volume of storage tank for HW heating	[l]		140			210	
Weight (Netto)	[kg]	113	137	152	127	151	166
Max. operating temperature / pressure in tank	[°C] / [bar]	90 / 3					
Max. operating temp. / pressure in HW storage tank	[°C] / [bar]	90 / 6					
Heat transfer surface of HW storage tank	[m ²]	1,43			1,95		
Capacity of hot water 40 °C at storage tank temp. 53 °C and inlet water 15 °C / HW flow rate*	[l] / [l·min ⁻¹]	260/5	490/5	750/5	260/ 10	490/ 10	750/ 10
Capacity of hot water 40 °C at storage tank temp 80 °C and inlet water 15 °C / HW flow rate*	[l] / [l·min ⁻¹]	650/5	1170/5	1450/5	650/ 10	1170/ 10	1450/ 10
Insulation thickness (Neodul LB PP)	[mm]	80					
Heat conductivity of insulation(Neodul LBPP)	[W·m ⁻¹ ·K ⁻¹]	0,032					
Insulation order number (Neodul LB PP)		6231902	6231904	6231905	6231902	6231904	6231905
Max. number × output of TPK 210-12	[pcs] × [kW]	1 × 12					
Max. number × output of TJ 6/4"	[pcs] × [kW]	1 × 9					
Energy efficiency class (Neodul LB PP)		B	C		B	C	
Standing loss (Neodul LB PP)	[W]	80	117	130	80	117	130

Tank dimensions		NADO 500/140 v1	NADO 750/140 v1	NADO 1000/140 v1	NADO 500/200 v1	NADO 750/200 v1	NADO 1000/200 v1
Tank diameter	∅ d	600	750	850	600	750	850
Total tank height	L	1970	2030	2040	1970	2030	2040
Tilting height	L _k	1990	2050	2060	1990	2050	2060
Tank height	H	1847	1903	1916	1847	1903	1916
Discharging connection	A	100	100	100	100	100	100
Z/T circuit socket	B	270	282	297	270	282	297
Z/T circuit socket	C	958	970	985	958	970	985
Z/T circuit socket	E	1644	1656	1671	1644	1656	1671
Sensor pocket socket	F	505	517	532	505	517	532
Sensor pocket socket	G	1554	1566	1581	1554	1566	1581
Flange socket	I	353	366	381	353	366	381
TJ 6/4" heating unit socket	J	937	950	965	-	-	-

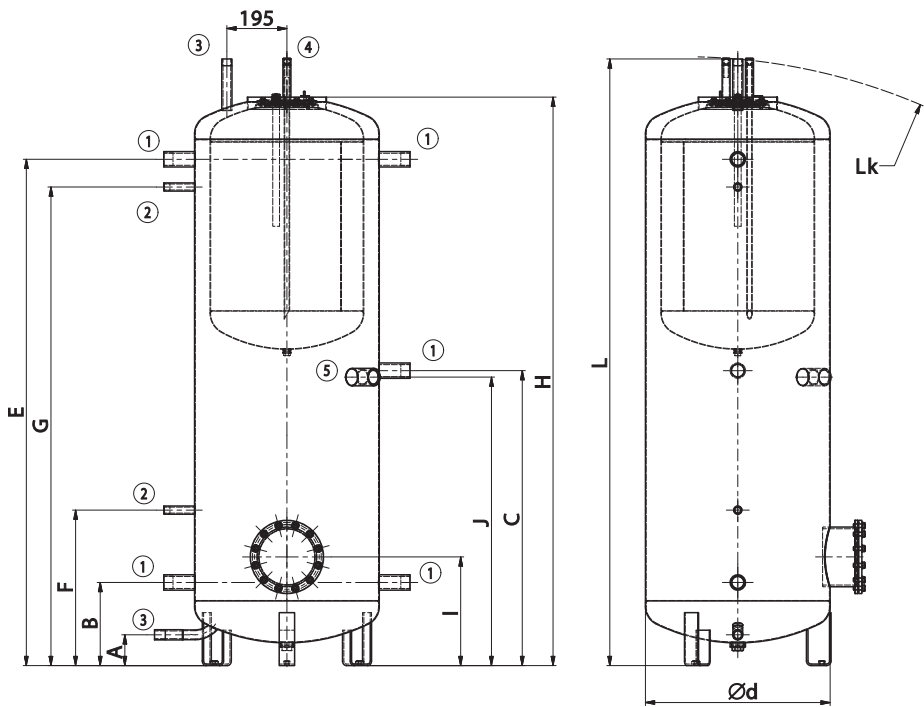

NADO 500/140 v1

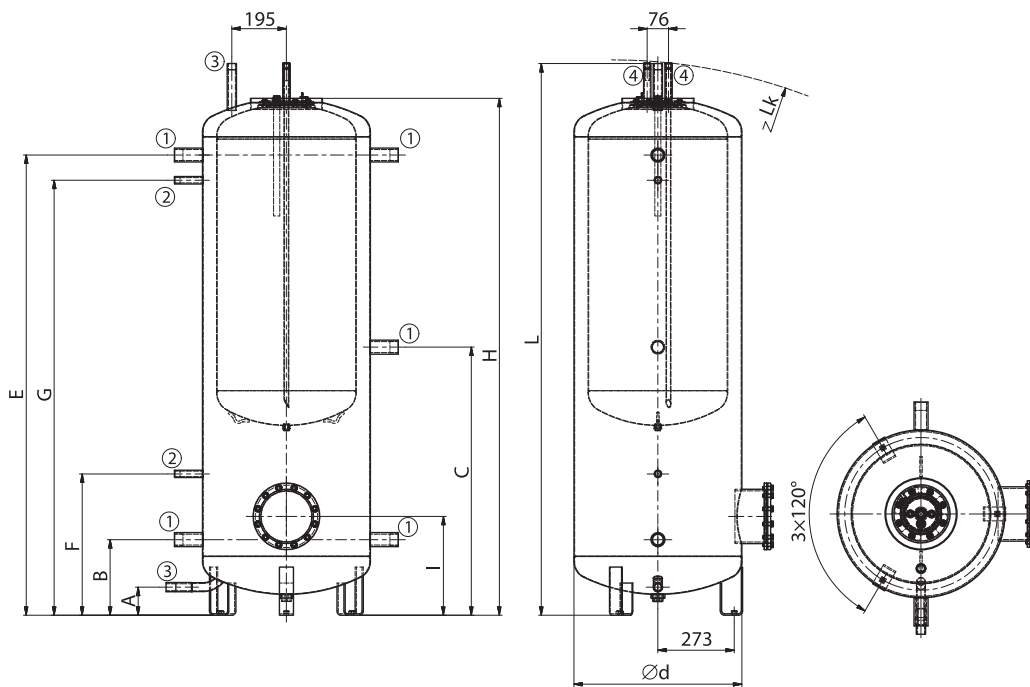

NADO 500/200 v1

NADO v1

STORAGE TANK

WITH DHW PREPARATION



- Types: 500, 750 l
- Inner HW storage tank in volumes of 300 and 250 l
- The tank is supplied without insulation
- Modern Neodul insulation can be ordered
- Suitable as a storage tank for heating systems with heat pumps
- The TJ 6/4" heating unit can be mounted into the socket

Socket dimensions	NADO 500/300 v1	Socket dimensions	NADO 750/250 v1
Socket 1 – female thread	1 ¼"	Socket 1 – female thread	1 ¼"
Socket 2 – female thread	½"	Socket 2 – female thread	1 ½"
Socket 3 – male thread	1"	Socket 3 – male thread	1"
Socket 5 – female thread	1 ½"	Socket 4 – male thread	¾"

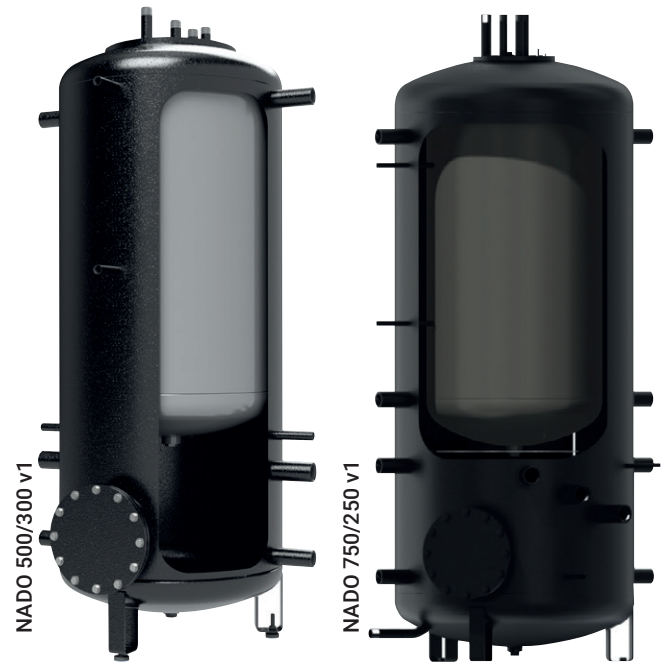

Technical parameters		NADO 500/300 v1	NADO 750/250 v1
Order number		121380314	121680314
Heating water volume in tank	[l]	475	772
Volume of storage tank for HW heating	[l]	279	260
Weight (Netto)	[kg]	153	180
Max. operating temperature / pressure in tank	[°C] / [bar]		90 / 3
Max. operating temperature / pressure in HW storage tank	[°C] / [bar]		90 / 6
Heat transfer surface of HW storage tank	[m²]	2,58	2,15
Capacity of hot water 40 °C at storage tank temperature 53 °C and inlet water 15 °C / HW flow rate*	[l] / [l·min ⁻¹]	260/ 10	490/ 10
Capacity of hot water 40 °C at storage tank temperature 80 °C and inlet water 15 °C / HW flow rate*	[l] / [l·min ⁻¹]	650/ 10	1170/ 10
Insulation thickness (Neodul LB PP)	[mm]		80
Heat conductivity of insulation (Neodul LBPP)	[W·m ⁻¹ ·K ⁻¹]		0,032
Insulation order number (Neodul LB PP)		6231947	6231915
Max. number × output of TJ 6/4"	[pcs] × [kW]	1 × 9	3 × 9
Energy efficiency class (Neodul LB PP)		B	C
Standing loss (Neodul LB PP)	[W]	80	117

Tank dimensions		NADO 500/300 v1
Tank diameter	∅ d	650
Total tank height	L	1821
Tilting height	L _k	1841
Tank height	H	1690
Z/T circuit socket	B	245
Z/T circuit socket	C	484
TJ 6/4" heating unit socket	E	1524
Sensor pocket socket	F	584
Sensor pocket socket	G	1036
Sensor pocket socket	I	327
Flange socket	J	1532

Tank dimensions		NADO 750/250 v1
Tank diameter	∅ d	750
Total tank height	L	2041
Tilting height	L _k	2063
Tank height	H	1914
Discharging connection	A	100
Z/T circuit socket	B	278
Z/T circuit socket	C	625
Z/T circuit socket	E	831
Z/T circuit socket	F	1656
Sensor pocket socket	G	278
Sensor pocket socket	I	625
Sensor pocket socket	J	1070
Sensor pocket socket	K	1566
TJ 6/4" heating unit socket	M	475
TJ 6/4" heating unit socket	N	535
TJ 6/4" heating unit socket	O	595
Flange socket	P	352

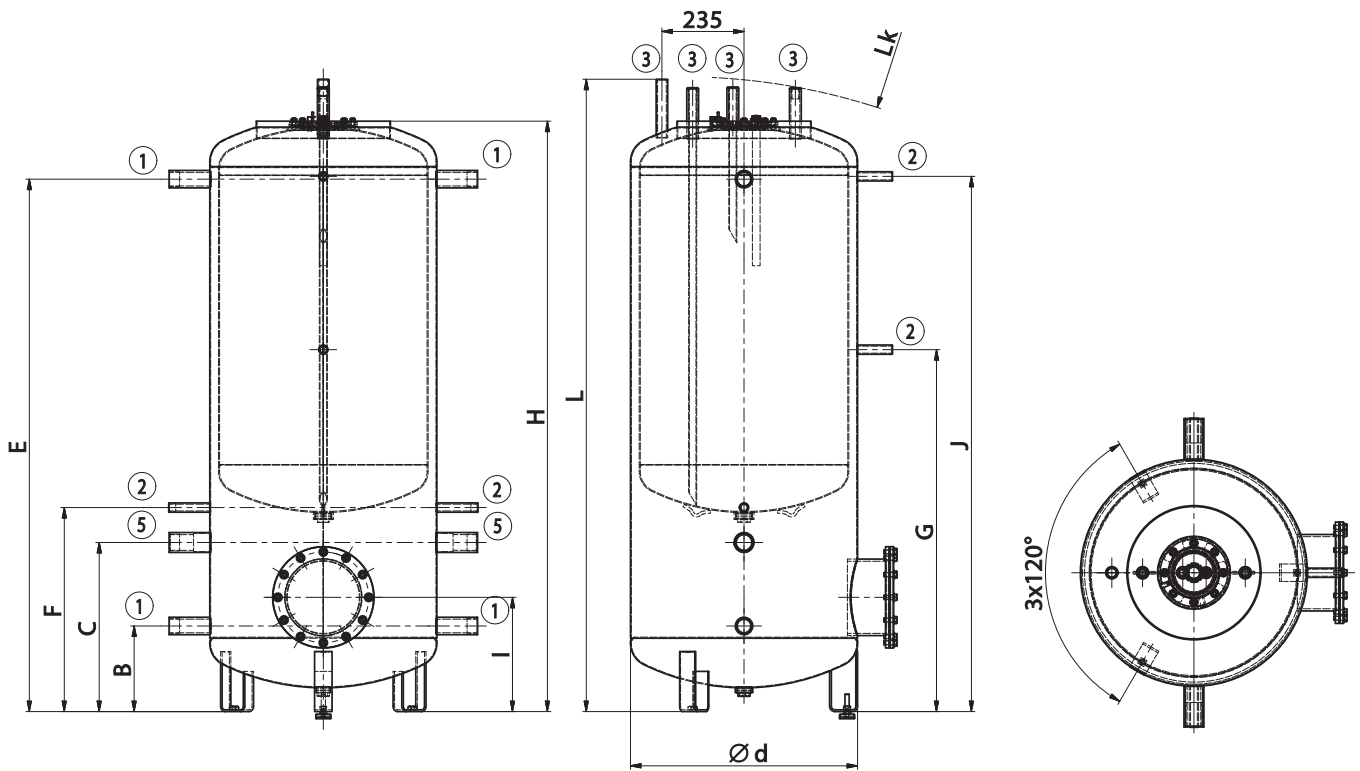

NADO 500/300 v1

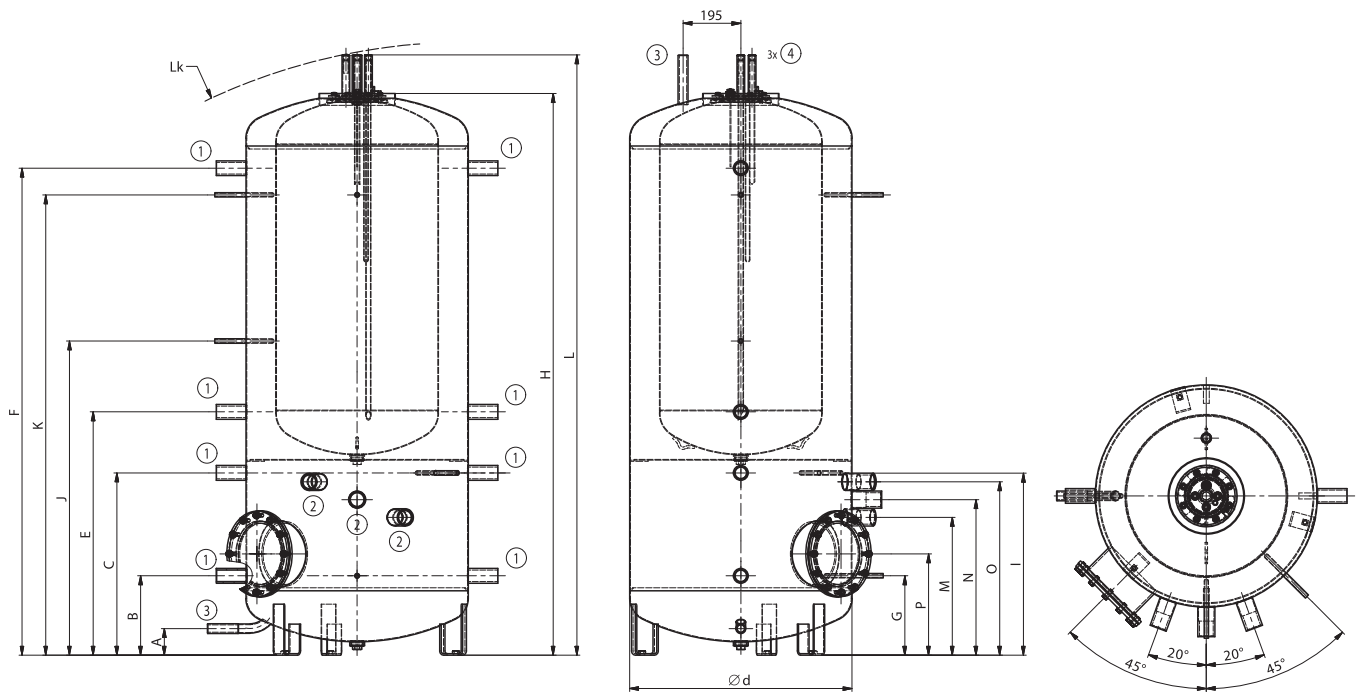

NADO 750/250 v1

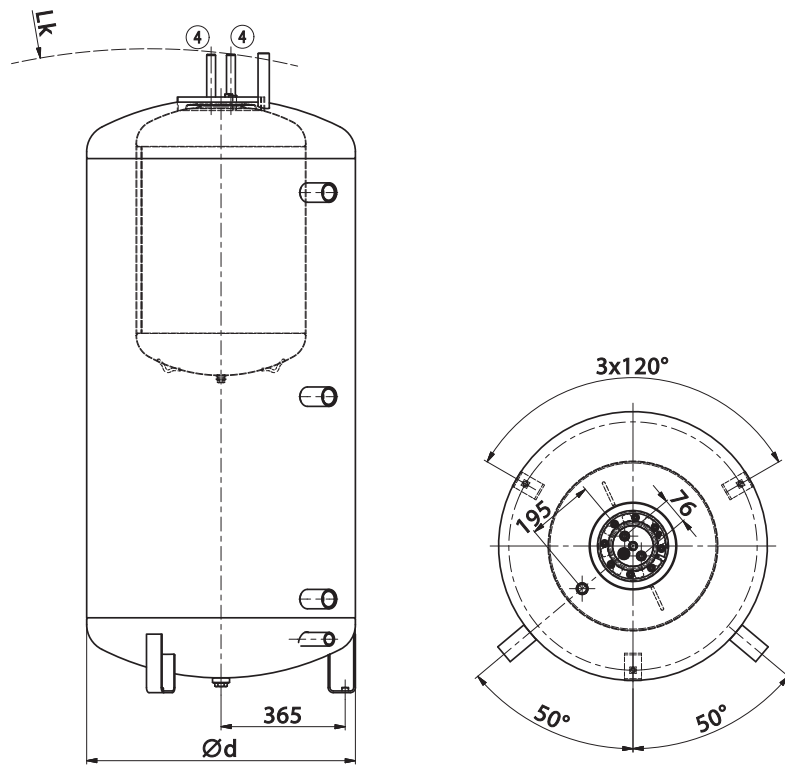
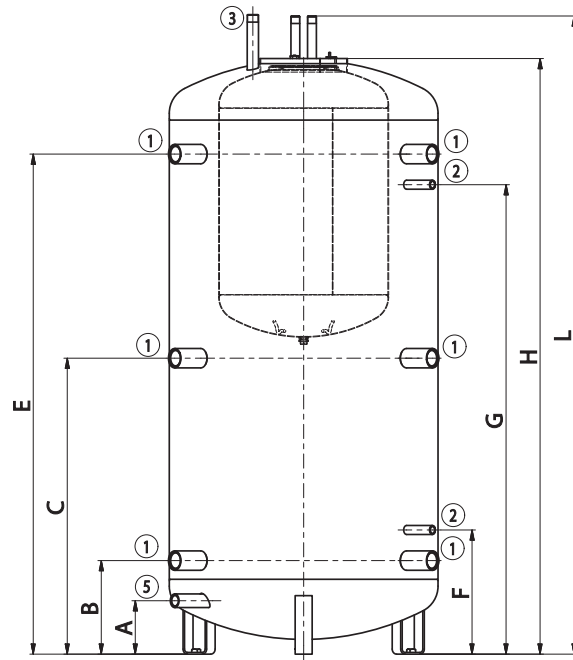

NADOS v1

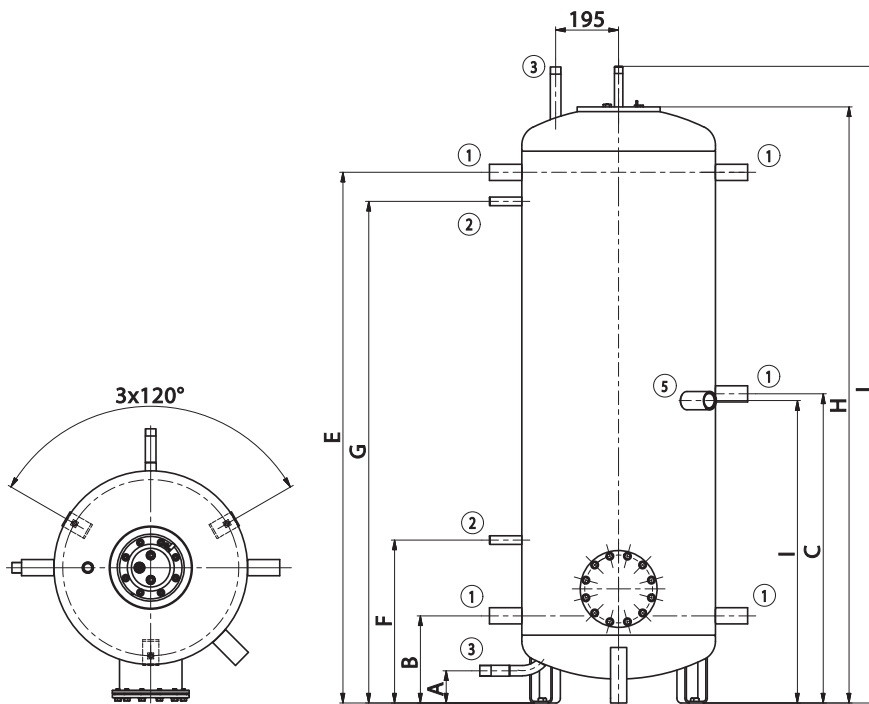
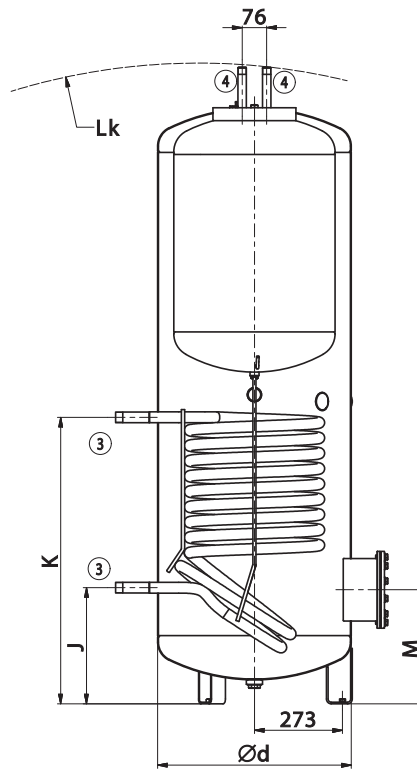

NADO 500/140 v2

NADOS v2

STORAGE TANK

WITH DHW PREPARATION



- Types: 800, 900 l
- Inner HW storage tank in a volume of 140 l
- The tank is supplied without insulation
- Modern Neodul insulation can be ordered
- Suitable as an equalization tank for heating systems with solid fuel boilers
- The TJ 6/4" heating unit can be mounted into the socket
- The tank is dimensioned for passage through the 80 cm door



Socket dimensions	NADOS 800/140 v2	NADOS 900/140 v2
Socket 1 – female thread		1 1/2"
Socket 2 – female thread		1/2"
Socket 3 – male thread		1"
Socket 4 – male thread		3/4"
Socket 5 – female thread		1"

Technical parameters		NADOS 800/140 v2	NADOS 900/140 v2
Order number		121880391	121880392
Heating water volume in tank	[l]	775	930
Volume of storage tank for HW heating	[l]		140
Weight (Netto)	[kg]	155	186
Max. operating temperature / pressure in tank	[°C] / [bar]		90 / 3
Max. operating temperature / pressure in HW storage tank	[°C] / [bar]		90 / 6
Heat transfer surface of HW storage tank	[m²]		1,43
Max. operating temperature / pressure in exchanger	[°C] / [bar]		110 / 10
Heat transfer surface of exchanger	[m²]		1,5
Exchanger volume flow rate	[m³·h⁻¹]		0,3
Exchanger volume	[l]		10,5
Capacity of hot water 40 °C at storage tank temperature 53 °C and inlet water 15 °C / HW flow rate*	[l] / [l·min⁻¹]	495/5	700/5
Capacity of hot water 40 °C at storage tank temperature 80 °C and inlet water 15 °C / HW flow rate*	[l] / [l·min⁻¹]	1175 / 5	1350 / 5
Insulation thickness (Neodul LB PP)	[mm]		80
Heat conductivity of insulation (Neodul LB PP)	[W·m⁻¹·K⁻¹]		0,032
Insulation order number (Neodul LB PP)		6232097	6232098
Max. number × output of TJ 6/4"	[pcs] × [kW]		1 × 3,75+1×9
Energy efficiency class (Neodul LB PP)			C
Standing loss (Neodul LB PP)	[W]	116	132

Tank dimensions		NADOS 800/140 v2	NADOS 900/140 v2
Tank diameter	∅ d	790	790
Total tank height	L	1880	2205
Tilting height	L _k	1900	2220
Tank height	H	1750	2075
Discharging connection	A	157	157
Z/T circuit socket	B	275	275
Z/T circuit socket	C	870	1020
Z/T circuit socket	E	1470	1795
Sensor pocket	F	365	365
Sensor pocket	G	1380	1705
Heat exchanger socket	J	275	275
Heat exchanger socket	K	803	803

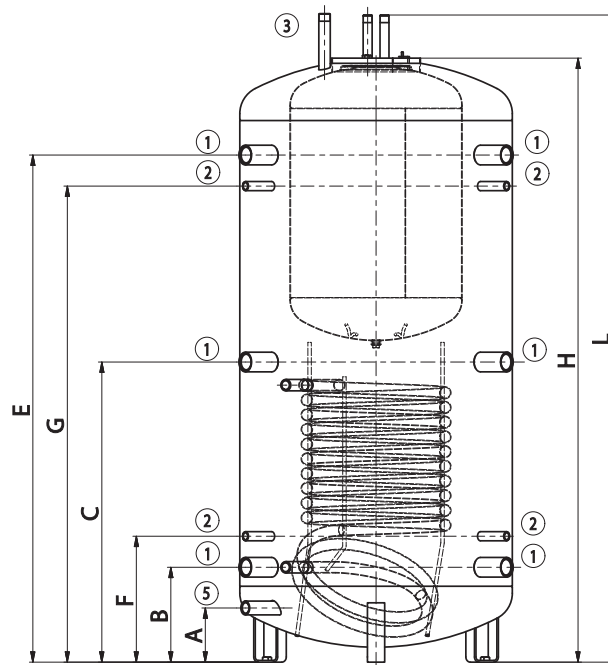
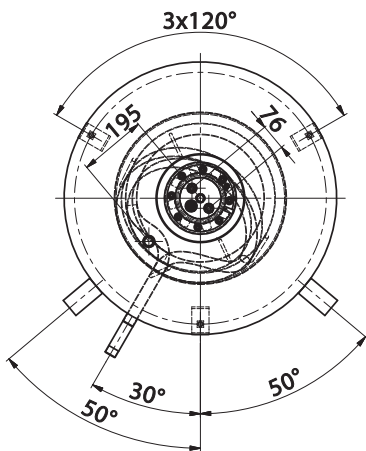
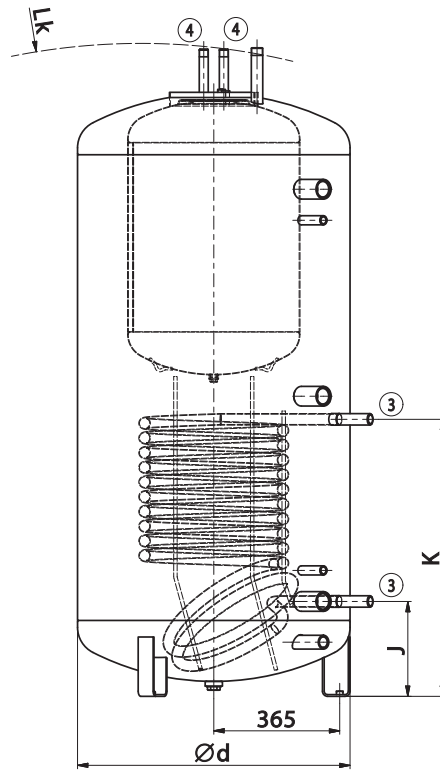

NADOS 800/140 v2

NADO v3

STORAGE TANK

WITH DHW PREPARATION



- Types: 500, 750, 1000 l
- Inner HW storage tank in a volume of 100 l
- The tank is supplied without insulation
- Modern Neodul insulation can be ordered
- Suitable as an storage tank for heating systems with solid fuel boilers and solar systems
- The TPK 210-12 heating unit can be mounted into the flange



Socket dimensions	NADO 500/100 v3	NADO 750/100 v3	NADO 1000/100 v3
Socket 1 – female thread		1 ¼"	
Socket 2 – female thread		½"	
Socket 3 – male thread		1"	
Socket 4 – male thread		¾"	

Technical parameters		NADO 500/100 v3	NADO 750/100 v3	NADO 1000/100 v3
Order number		121380388	121680388	121580388
Heating water volume in tank	[l]	475	772	999
Volume of storage tank for HW heating	[l]		92	
Weight (Netto)	[kg]	168	195	202
Max. operating temperature / pressure in tank	[°C] / [bar]		90 / 3	
Max. operating temperature / pressure in HW storage tank	[°C] / [bar]		90 / 6	
Heat transfer surface of HW storage tank	[m ²]		1,25	
Max. operating temperature / pressure in exchanger	[°C] / [bar]		110 / 10	
Heat transfer surface of exchanger (top / bottom)	[m ²]		1,5 / 1,5	
Exchanger volume (top / bottom)	[l]		10,5 / 10,5	
Capacity of hot water 40 °C at storage tank temperature 53 °C and inlet water 15 °C / HW flow rate**	[l] / [l·min ⁻¹]	260/5	490/5	750/5
Capacity of hot water 40 °C at storage tank temperature 80 °C and inlet water 15 °C / HW flow rate**	[l] / [l·min ⁻¹]	650/5	1170/5	1450/5
Insulation thickness (Neodul LB PP)	[mm]		80	
Heat conductivity of insulation (Neodul LB PP)	[W·m ⁻¹ ·K ⁻¹]		0,032	
Insulation order number (Neodul LB PP)		6231902	6231904	6231905
Max. number × output of TPK 210-12	[pcs] × [kW]	1 × 6		1 × 12
Exchanger volume flow rate	[m ³ ·h ⁻¹]		0,3	
Energy efficiency class (Neodul LB PP)		B		C
Standing loss (Neodul LB PP)	[W]	80	117	130

Tank dimensions		NADO 500/100 v3	NADO 750/100 v3	NADO 1000/100 v3
Tank diameter	∅ d	600	750	850
Total tank height	L	1970	2030	2040
Tilting height	L _k	1990	2050	2060
Tank height	H	1847	1903	1916
Discharging connection	A	100	100	100
Z/T circuit socket	B	270	282	297
Z/T circuit socket	C	958	970	985
Z/T circuit socket	E	1644	1656	1671
Sensor pocket socket	F	505	517	532
Sensor pocket socket	G	1554	1566	1581
Heat exchanger socket	I	360	344	387
Heat exchanger socket	J	888	872	915
Heat exchanger socket	K	1060	1043	1089
Heat exchanger socket	M	1588	1571	1617
Flange socket	N	353	366	381

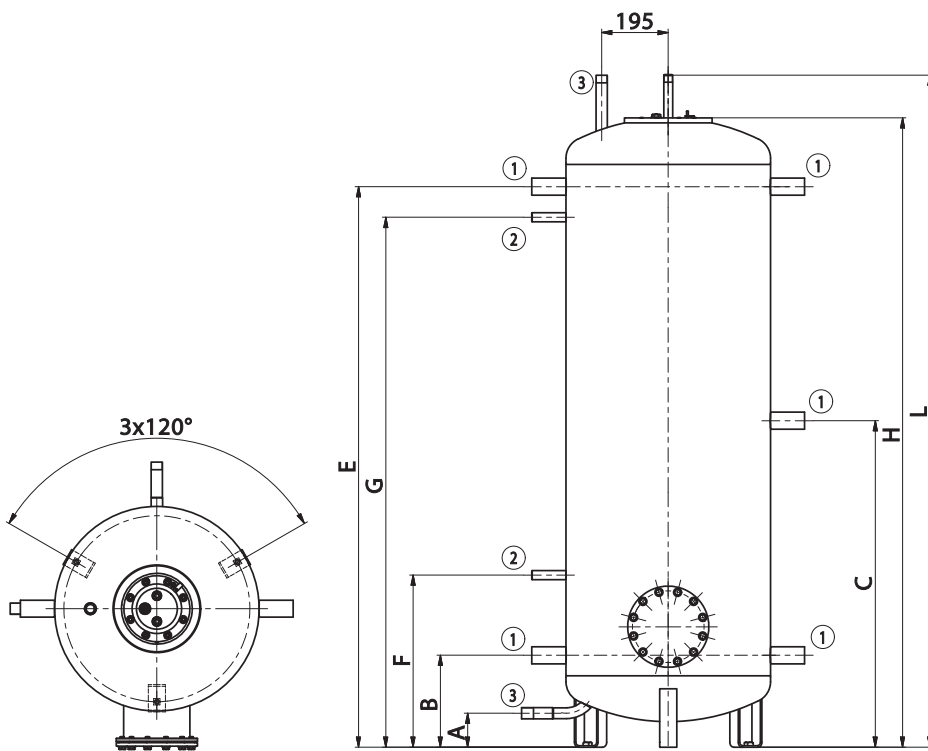
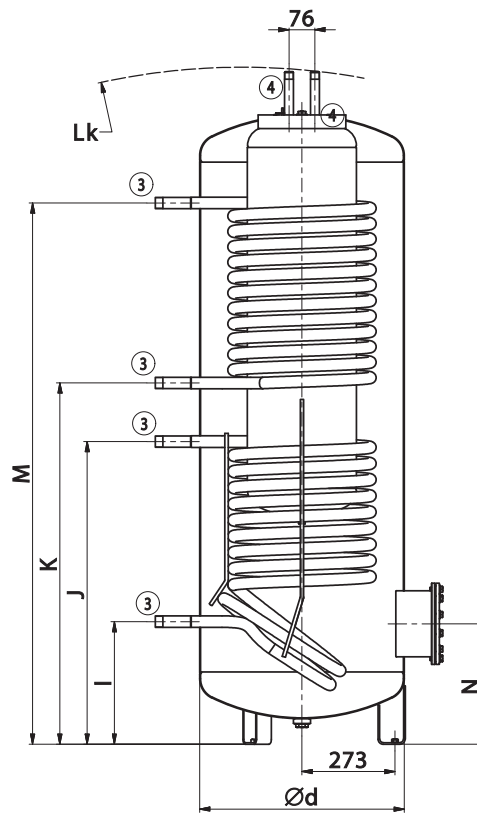

NADO 500/100 v3

NADO v6

STORAGE TANK

WITH DHW PREPARATION



- Types: 300, 500, 750, 1000 l
- Heating by HW flow in a stainless steel exchanger with an above-average heat transfer surface
- The tank is available with insulation in a volume of 300 l and without insulation in volumes of 500, 750, and 1000 l
- Modern Neodul insulation can be ordered
- Various heat sources can be connected such as biomass, coal, gas and electric boilers, heat pumps and solar collectors
- The TJ 6/4" electric cartridges can be mounted into sockets no. 4

Socket dimensions	NADO 300/20 v6	NADO 500/25 v6	NADO 750/35 v6	NADO 1000/45 v6
Socket 1 – female thread			1 ¼"	
Socket 2 – male thread			1"	
Socket 3 – female thread			½"	
Socket 4 – female thread			1 ½"	
Socket 5 – male thread			1 ¼"	

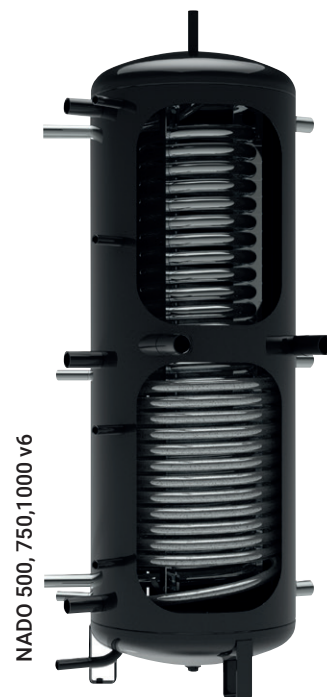

Technical parameters		NADO 300/20 v6	NADO 500/25 v6	NADO 750/35 v6	NADO 1000/45 v6
Order number		121080398	121380350	121680350	121580350
Heating water volume in tank	[l]	358	475	772	999
Exchanger volume for HW heating	[l]	20	23	32	37
Weight (Netto)	[kg]	106	134	165	197
Max. operating temperature / pressure in tank	[°C] / [bar]	90 / 3			
Max. operating temperature / pressure in exchanger TV	[°C] / [bar]	90 / 6			
Max. operating temperature / pressure in heat exchanger	[°C] / [bar]	110 / 10			
Heat transfer surface of exchanger TV	[m²]	4,5	6,25	8,5	10
HW exchanger volume flow rate	[m³·h⁻¹]	0,6			
Heat transfer surface of heat exchanger (top / bottom)	[m²]	- / 1,6	- / 2,2	- / 2,2	- / 3,3
Heat exchanger volume (top / bottom)	[l]	- / 12	- / 18	- / 18	- / 25
Capacity of hot water 40 °C at storage tank temperature 53 °C and inlet water 15 °C / HW flow rate*	[l] / [l·min⁻¹]	210 / 10	260 / 10	490 / 10	750 / 10
Capacity of hot water 40 °C at storage tank temperature 80 °C and inlet water 15 °C / HW flow rate*	[l] / [l·min⁻¹]	520 / 10	650 / 10	1170 / 10	1450 / 10
Insulation thickness (Neodul LB PP)	[mm]	60	80		
Heat conductivity of insulation (Neodul LB PP)	[W·m⁻¹·K⁻¹]	0,032			
Insulation order number (Neodul LB PP)		tank component	6231957	6231958	6231959
Max. num. x out. of TJ 6/4" h. unit with extended cooling section	[pcs] x [kW]	2 x 4,5	2 x 6		
Energy efficiency class (Neodul LB PP)		C			
Standing loss (Neodul LB PP)	[W]	97	91	114	148

Tank dimensions		NADO 300/20 v6	NADO 500/25 v6	NADO 750/35 v6	NADO 1000/45 v6
Tank diameter	∅ d	550	600	750	850
Tank diameter with insulation	∅ D	670	-	-	-
Total tank height	L	1705	1970	2030	2040
Tilting height	L _k	1820	1990	2050	2060
Tank height	H	-	1847	1903	1916
Discharging connection	A	80	100	100	100
Z/T circuit socket	B	238	262	280	297
Z/T circuit socket	C	-	952	1018	1040
Z/T circuit socket	E	1438	1662	1680	1700
Socket TV – inlet	F	1299	312	320	380
Socket TV – outlet	G	1440	1612	1680	1700
Solar exchanger socket – outlet	I	228	245	270	280
Solar exchanger socket – inlet	J	756	905	884	980
Sensor pocket socket	K	458	392	415	463
Sensor pocket socket	M	-	762	742	755
Sensor pocket socket	N	-	1282	1219	1213
Sensor pocket socket	O	1348	1662	1695	1715
TJ 6/4" heating unit socket	P	816	992	1017	1040
TJ 6/4" heating unit socket	R	100	225	290	340

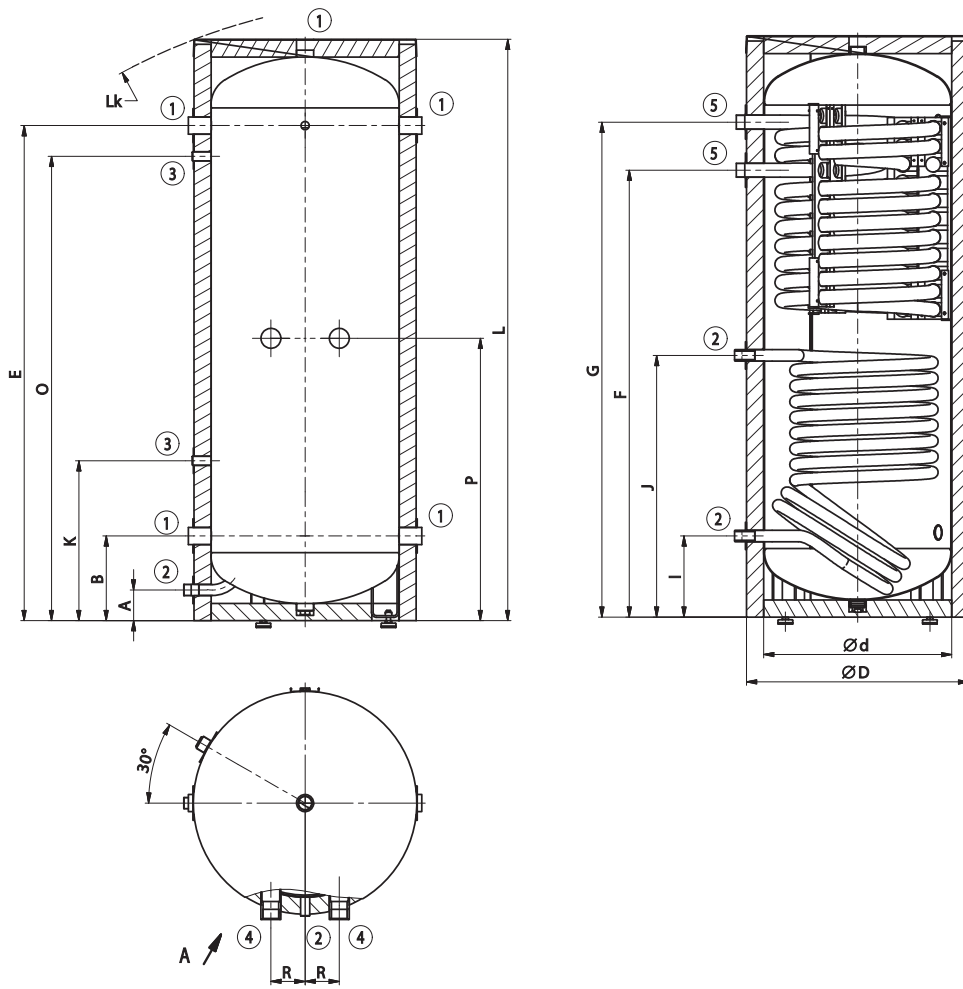

NADO 300/20 v6

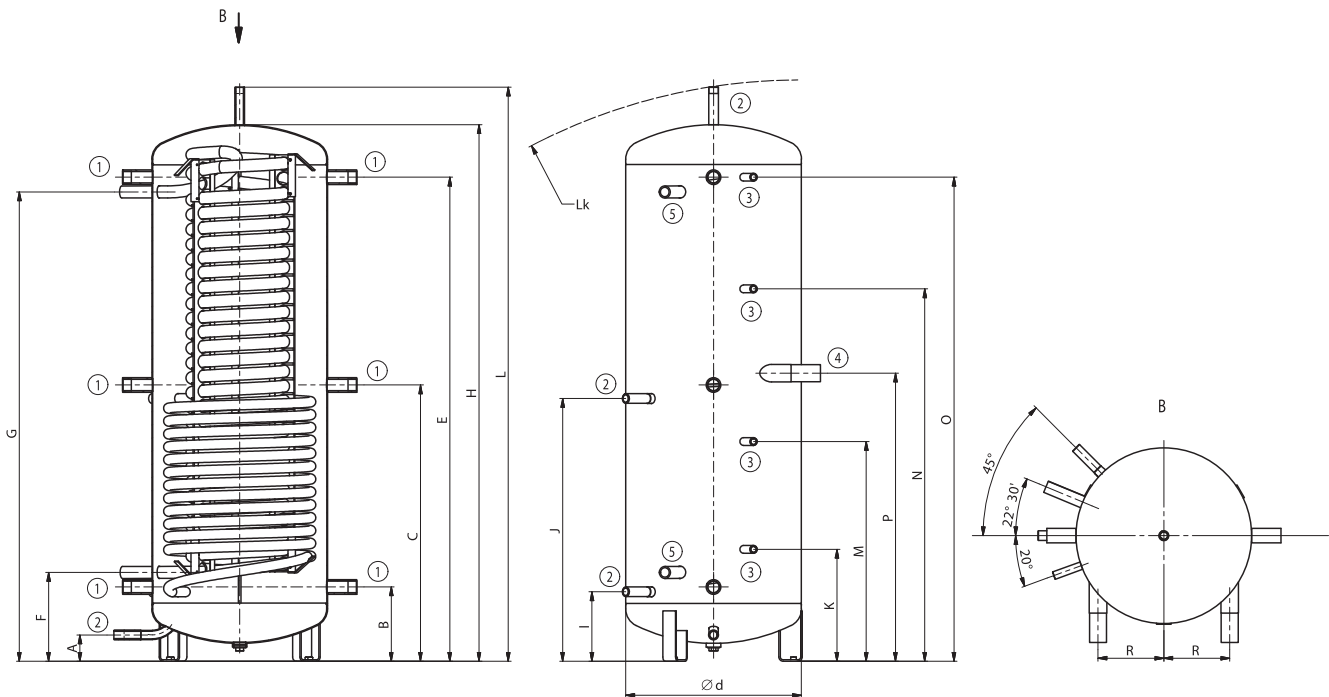

NADO 500, 750, 1000 v6

NADO v7

STORAGE TANK

WITH DHW PREPARATION



- Types: 500, 750, 1000 l
- HW heating in inner storage tank 200 l
- The tank is supplied without insulation
- Modern Neodul insulation can be ordered
- Various heat sources can be connected such as biomass, coal, gas and electric boilers, heat pumps and solar collectors
- The TJ 6/4" heating unit can be mounted into sockets no. 5

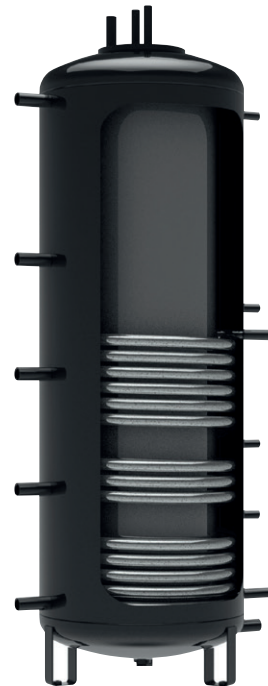

Socket dimensions	NADO 500/200 v7	NADO 750/200 v7	NADO 1000/200 v7
Socket 1 – female thread		1"	
Socket 2 – female thread		½"	
Socket 3 – male thread		1"	
Socket 4 – male thread		¾"	
Socket 5 – female thread	–		1 ½"

Technical parameters		NADO 500/200 v7	NADO 750/200 v7	NADO 1000/200 v7
Order number		121380373	121880354	121780354
Heating water volume in tank	[l]	475	772	999
Volume of storage tank for HW heating	[l]		233	
Weight (Netto)	[kg]	175	212	243
Max. operating temperature / pressure in tank	[°C] / [bar]		90 / 3	
Max. operating temperature / pressure in HW storage tank	[°C] / [bar]		90 / 6	
Max. operating temperature / pressure in exchanger	[°C] / [bar]		110 / 10	
Heat transfer surface of HW storage tank	[m ²]		2,29	
Exchanger volume flow rate	[m ³ ·h ⁻¹]		0,6	
Heat transfer surface of HW storage tank	[m ²]	2,5		3,3
Heat exchanger volume	[l]	18		25
Capacity of hot water 40 °C at storage tank temperature 53 °C and inlet water 15 °C / HW flow rate*	[l] / [l·min ⁻¹]	260 / 10	490 / 10	750 / 10
Capacity of hot water 40 °C at storage tank temperature 80 °C and inlet water 15 °C / HW flow rate*	[l] / [l·min ⁻¹]	650 / 10	1170 / 10	1450 / 10
Insulation thickness (Neodul LB PP)	[mm]		80	
Heat conductivity of insulation (Neodul LB PP)	[W·m ⁻¹ ·K ⁻¹]		0,032	
Insulation order number (Neodul LB PP)		6231923	6231956	6231948
Max. num. × out. of TJ 6/4" h. unit with extended cooling section	[pcs] × [kW]	–		2 × 6
Energy efficiency class (Neodul LB PP)		B		C
Standing loss (Neodul LB PP)	[W]	76	113	126

Tank dimensions		NADO 500/200 v7	NADO 750/200 v7	NADO 1000/200 v7
Tank diameter	Ø d	600	790	790
Total tank height	L	1982	1954	2242
Tilting height	L _x	2002	1994	2310
Tank height	H	1835	1815	2115
Discharging connection	A	146	157	159
Z/T circuit socket	B	249	259	261
Z/T circuit socket	C	574	585	587
Z/T circuit socket	E	901	911	913
Z/T circuit socket	F	1226	1237	1239
Z/T circuit socket	G	–	–	1565
Z/T circuit socket	I	1679	1609	1911
Sensor pocket socket	J	477	469	471
Sensor pocket socket	K	690	689	691
Sensor pocket socket	M	1099	1109	1111
Sensor pocket socket	N	–	–	1411
Sensor pocket socket	O	–	1609	1901
Solar exchanger socket – outlet	P	239	249	251
Solar exchanger socket – inlet	R	1019	909	911
TJ 6/4" heating unit socket	S	–	1074	1076
TJ 6/4" heating unit socket	T	–	275	275

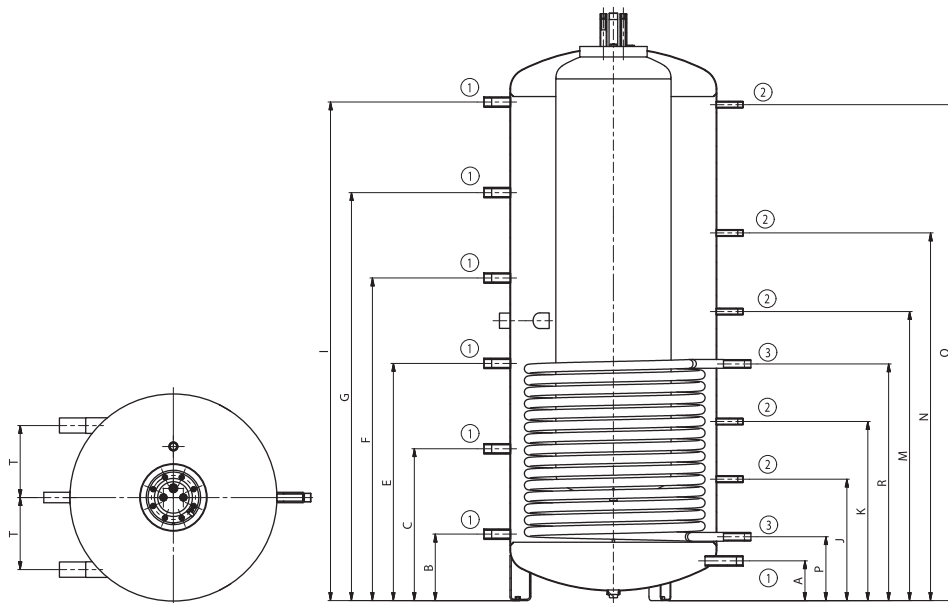
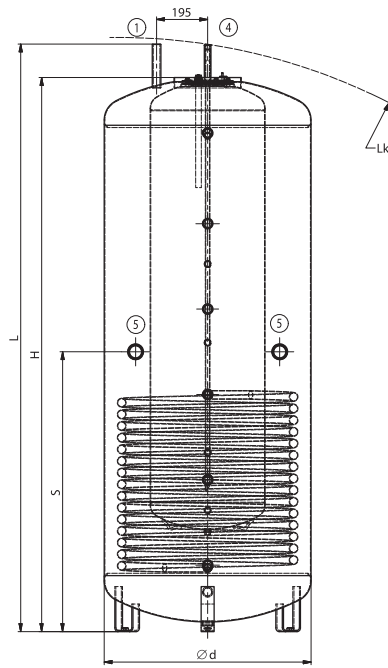

NADO 1000/200 v7

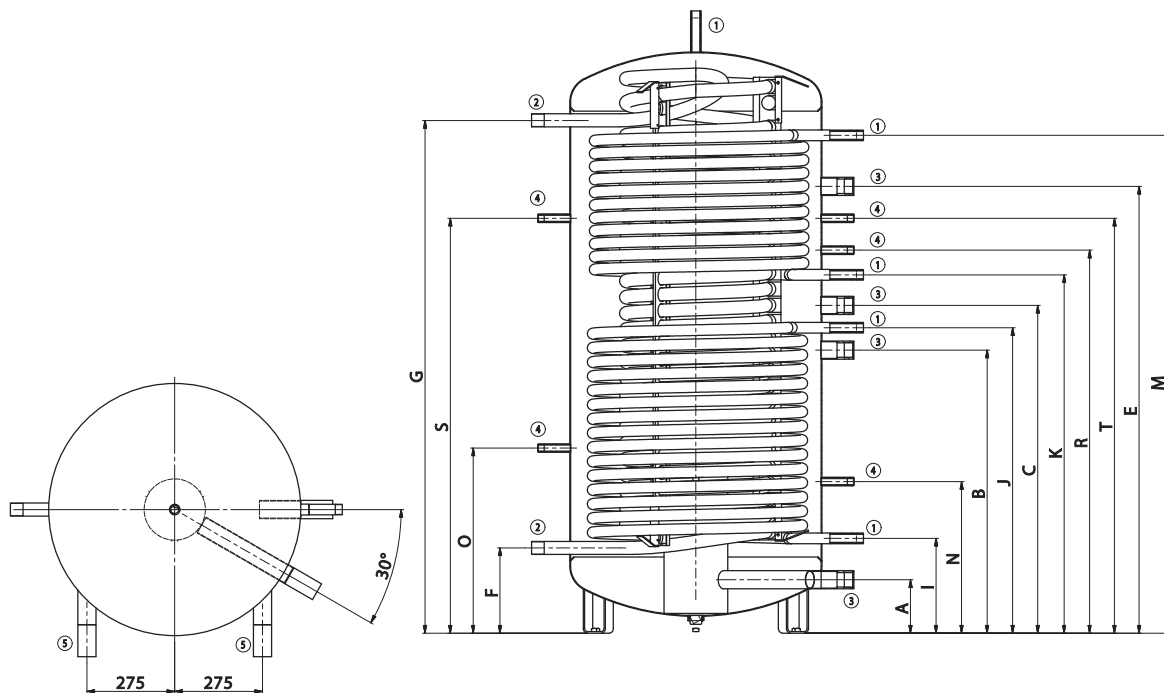
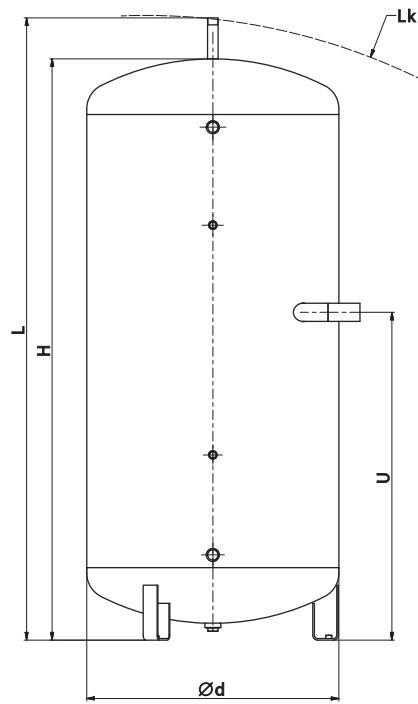

NADO 800/35 v9

NADO v11

STORAGE TANK

WITH DHW PREPARATION



- Types: 300, 400, 750, 1000 l
- Heating by HW flow in a stainless steel exchanger with an above-average heat transfer surface
- The tank is available with insulation in a volume of 300 and 400 l and without insulation in volumes of 750 and 1000 l
- Modern Neodul insulation can be ordered
- Various heat sources can be connected – suitable especially for heat pumps with photovoltaic
- The TJ 6/4" heating unit can be mounted into sockets no. 4
- The TPK 210-12 heating unit can be mounted into the flange

Socket dimensions	NADO 300/20 v11	NADO 400/20 v11	NADO 750/25 v11	NADO 1000/25 v11
Socket 1 – female thread		1 ¼"		
Socket 2 – male thread		1"		
Socket 3 – female thread		½"		
Socket 4 – female thread		1 ½"		
Socket 5 – male thread		1 ¼"		

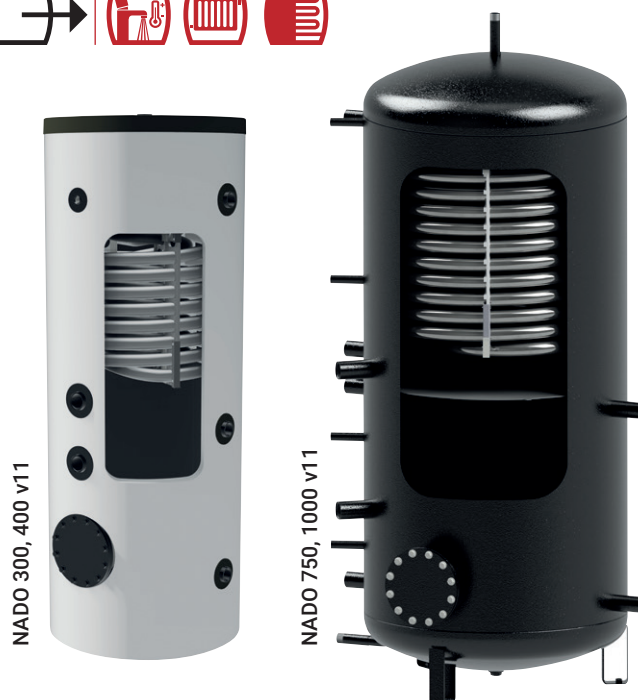

Technical parameters		NADO 300/20 v11	NADO 400/20 v11	NADO 750/25 v11	NADO 1000/25 v11
Order number		1210803160	1214803160	1218803147	1215803147
Heating water volume in tank	[l]	320	405	772	999
Volume of storage tank for HW heating	[l]		20		23
Weight (Netto)	[kg]	106	122	165	197
Max. operating temperature / pressure in tank	[°C] / [bar]			90 / 3	
Max. operating temperature / pressure in exchanger HW	[°C] / [bar]			90 / 6	
Heat transfer surface of exchanger TV	[m²]		4,5		6,25
HW exchanger volume flow rate	[m³·h⁻¹]			0,6	
Capacity of hot water 40 °C at storage tank temperature 53 °C and inlet water 15 °C / HW flow rate*	[l] / [l·min⁻¹]	210 / 10*	220 / 10*	240 / 10*	260 / 10*
Capacity of hot water 40 °C at storage tank temperature 80 °C and inlet water 15 °C / HW flow rate*	[l] / [l·min⁻¹]	520 / 10*	540 / 10*	610 / 10*	650 / 10
Insulation thickness (Neodul LB PP)	[mm]		60		80
Heat conductivity of insulation (Neodul LB PP)	[W·m⁻¹·K⁻¹]			0,032	
Insulation order number (Neodul LB PP)			tank component	6232093	6232092
Max. number × output of TPK 210-12	[pcs] × [kW]		1 × 6		1 × 12
Max.number×outputof TJ 6/4" h. unit with extended cooling section	[pcs] × [kW]		2 × 6		2 × 9
Energy efficiency class (Neodul LB PP)				C	
Standing loss (Neodul LB PP)	[W]	97	113	114	148

Tank dimensions		NADO 300/20 v11	NADO 400/20 v11	NADO 750/25 v11	NADO 1000/25 v11
Tank diameter	∅ d	550	550	790	850
Tank diameter with insulation	∅ D	670	670	–	–
Total tank height	L	1702	1902	2035	2061
Tilting height	L _t	1821	2010	2073	2104
Tank height	H	–	–	1907	1932
Discharging connection	A	90	90	100	100
Z/T circuit socket	B	248	248	280	297
Z/T circuit socket	C	726	818	868	885
Z/T circuit socket	E	–	–	980	997
Z/T circuit socket	F	1448	1648	1680	1697
Flange socket	G	340	340	374	391
Socket TV – inlet	I	1308	1508	1050	1067
Socket TV – outlet	J	1448	1648	1630	1647
Sensor pocket socket	K	468	468	415	432
Sensor pocket socket	M	1358	1558	742	759
Sensor pocket socket	N	1448	1648	1219	1236
Sensor pocket socket	O	–	–	1695	1712
TJ 6/4" heating unit socket	P	626	718	555	572
TJ 6/4" heating unit socket	Q	826	918	980	997

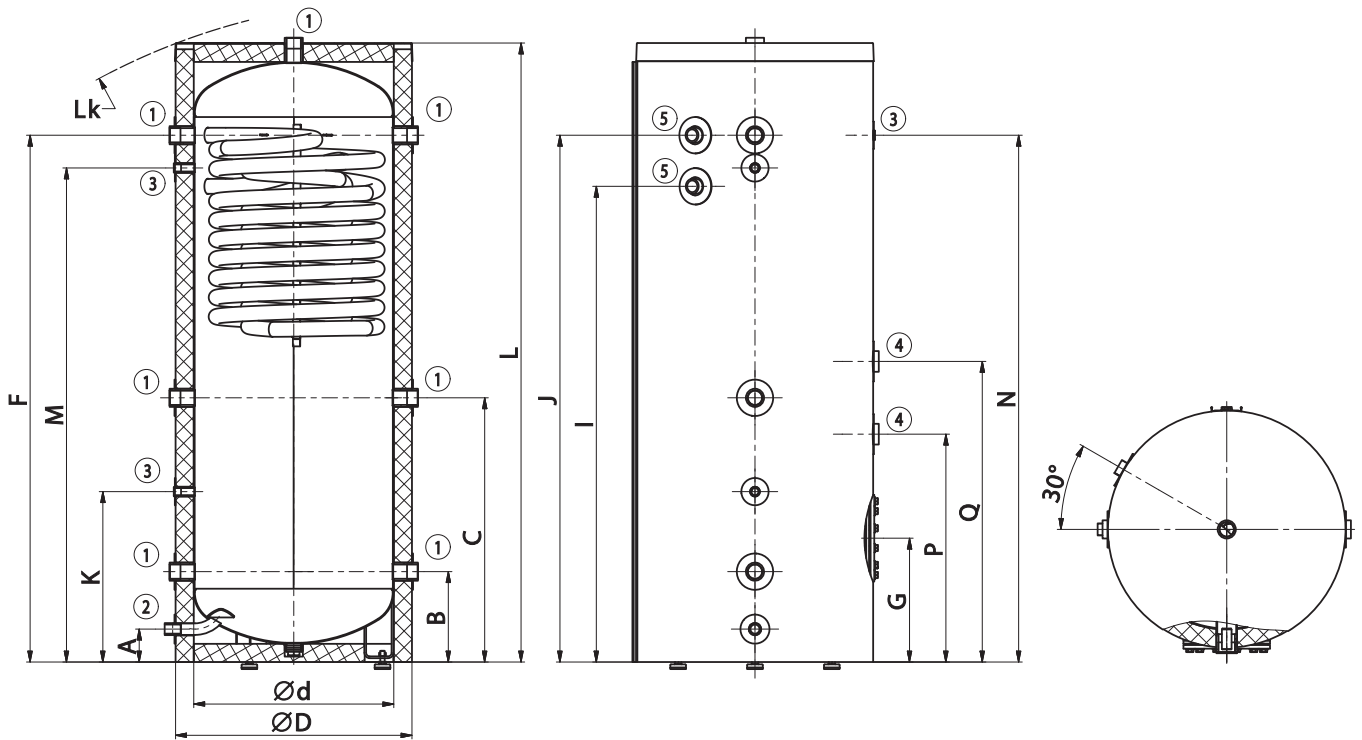

NADO 300, 400/20 v11

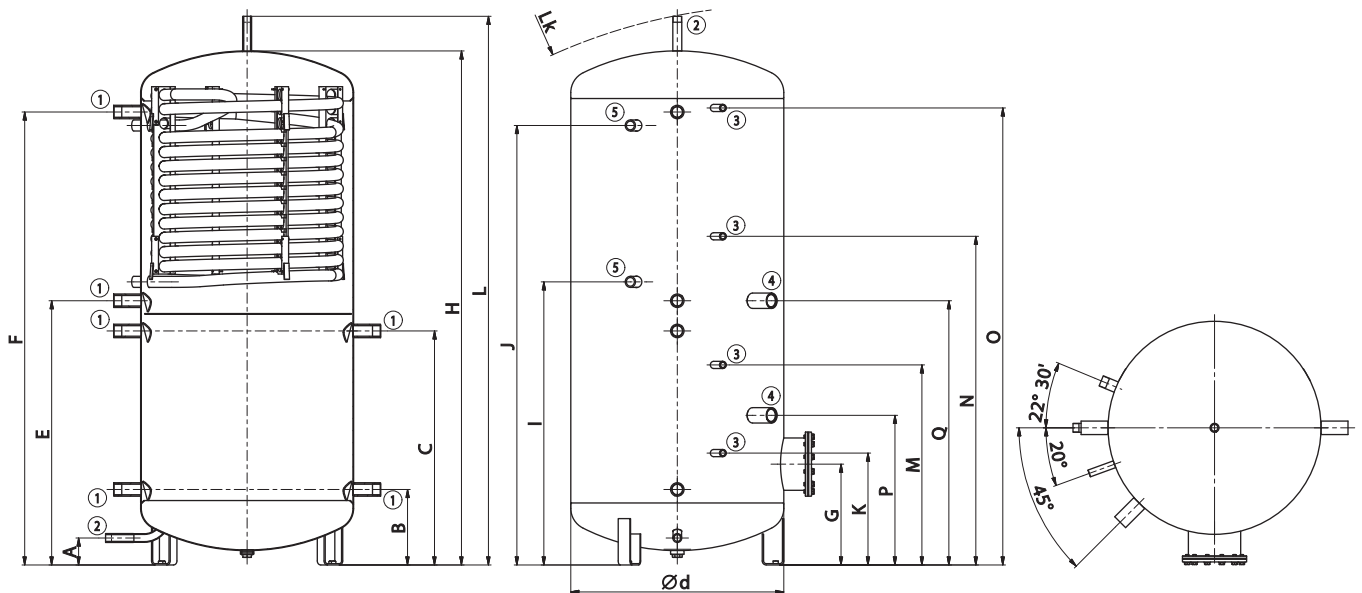

NADO 750, 1000/25 v11

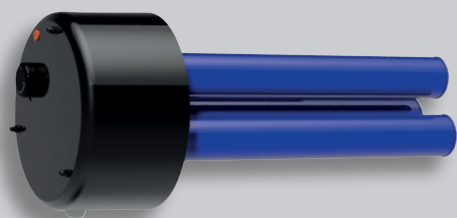



ACCESSORIES

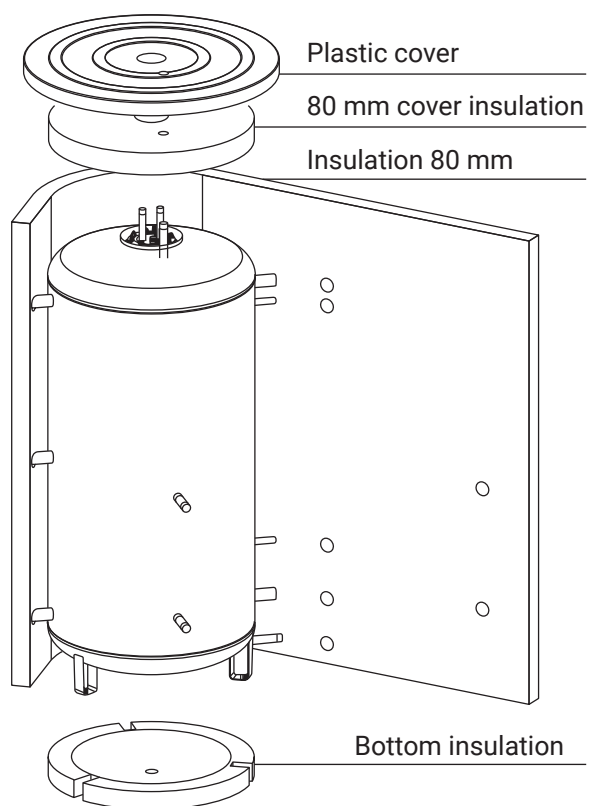

- Standard delivery with most tanks
- The first and only category B series insulation on the market
- Standard thickness of insulation is 80 mm
- Example of heat loss for 500 l tank: 1.9 kWh / 24 h with an insulation thickness of 80 mm
- The delivery includes a top cover, flange covers and hole caps
- The NAD 50, 100, 250 v1 and UKV 300, 500 tanks are supplied with polyurethane insulation

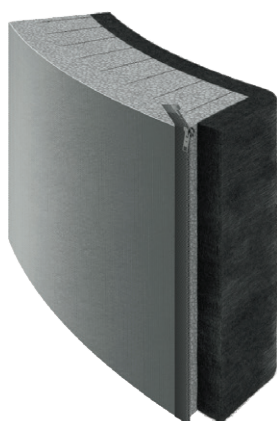

Insulation cut with fastener

IPS ProtectX

IPS - IONIZATION POLARIZATION SYSTEM

Equipment for the physical treatment of water in connection with the reduction of limestone for the protection of household appliances and water distribution systems



ADVANTAGES

- It prolongs the service life of heating equipment and sanitary equipment
- No external power supply
- Maintenance free
- Zero additional costs
- It does not use any chemicals
- Negligible pressure losses
- Patented product
- Certified effectiveness
- Blue line - suitable for all types of water supply, in addition it contains disinfectants, suitable e.g. for untreated water sources
- Red line - suitable for all types of water supply

INDICATIVE DIAGRAM OF THE IPS ProtectX EQUIPMENT LOCATION

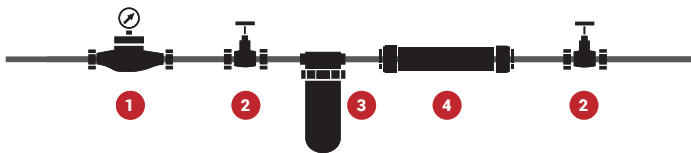

1. Consumption meter
2. Shut-off valve
3. Mechanical dirt filter
4. IPS ProtectX

Order number	TYPE	DIMENSIONS (d × l)	MAXIMUM FLOW
100671000	ProtectX G 1/2" (red line)	50 × 245 mm	1 m ³ /h
100671001	ProtectX G 3/4" (red line)	50 × 245 mm	3,2 m ³ /h
100671002	ProtectX G 1" (red line)	50 × 251 mm	4 m ³ /h
100671003	ProtectX G 1/2" (blue line)	50 × 245 mm	1 m ³ /h
100671004	ProtectX G 3/4" (blue line)	50 × 245 mm	3,2 m ³ /h
100671005	ProtectX G 1" (blue line)	50 × 251 mm	4 m ³ /h

PROTECT CH

MINI CHEMICAL WATER TREATMENT PLANT

Chemical water treatment plant for water that protects pipes and equipment against limescale deposits with a replaceable polyphosphate capsule.



ADVANTAGES:

- Extends the service life of hot water heating appliance
- Installation on cold water supply in horizontal and vertical position
- Replaceable polyphosphate capsule, service life 1 – 2 months
- Maximum flow rate 1 200 l/hr
- The plant does not require a connection to electrical energy

Order Number: 100671022

ORIGINAL PARTS FROM DRAŽICE

- 24 month warranty period
- Reliability and high quality
- Guarantee of functionality and safety
- Guaranteed long life
- Identical components used in manufacturing
- Easy availability throughout the Czech Republic

ANODE WITH EXTERNAL POWER SUPPLY

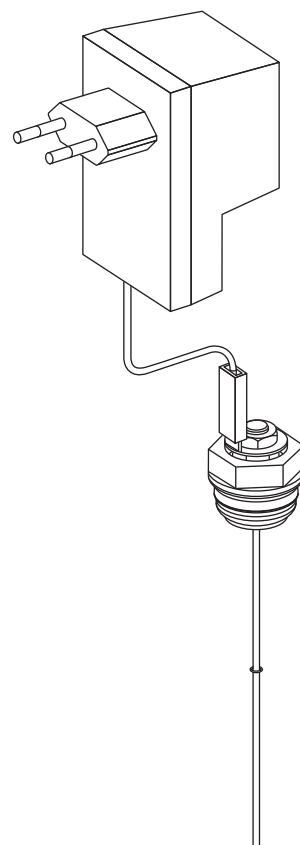
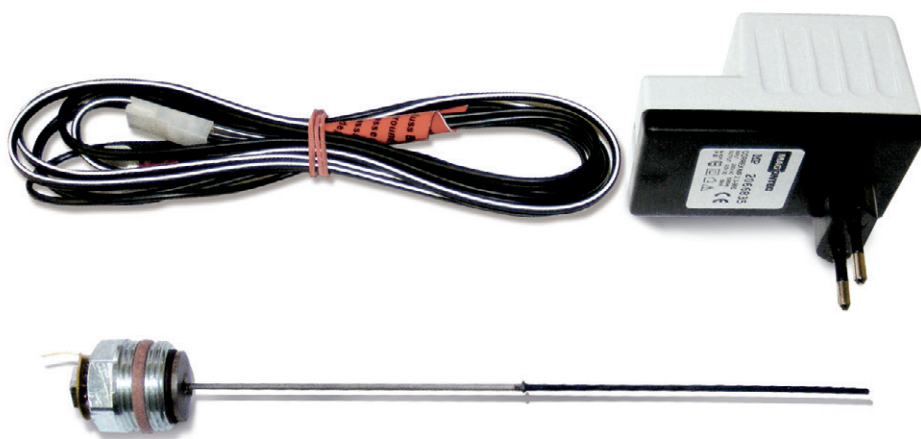

- Used for protection of inner enamel storage tanks and extends their life span
- Usable up to a volume of 300 l
- Maintenance free, wear proof
- To order

Order number	6199209
Diameter	2 mm
Length	200 mm
Coat length	100 mm

FLANGED HEATING UNITS WITH CERAMIC BODY TPK

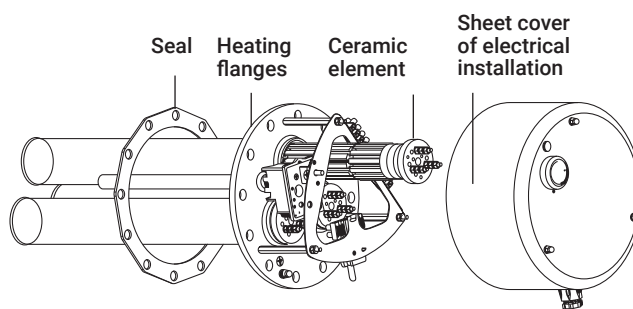
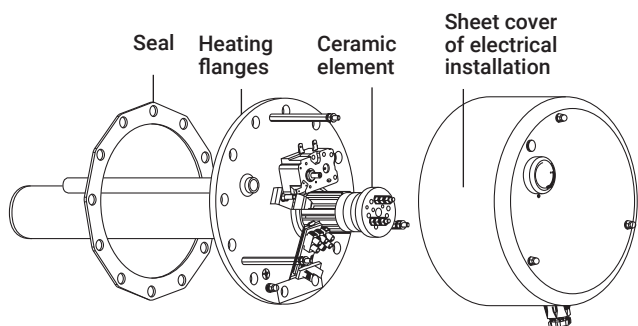

TPK – single-phase

TPK – three-phase

ORIGINAL PARTS FROM DRAŽICE

SCREW-TYPE ELECTRICAL HEATING UNITS OF THE TJ SERIES

Type		TJ 6/4" -2	TJ 6/4" -2,5	TJ 6/4" S -2,5	TJ 6/4" -3,3	TJ 6/4" -3,75	TJ 6/4" -4,5	TJ 6/4" -6	TJ 6/4" S -6	TJ 6/4" -7,5	TJ 6/4" -9
Order number L/L1		- / 2110353	- / 2110354	- / 2110361	2110355 / -	- / 2110356	- / 2110357	- / 2110358	- / 2110351	2110362 / 2110359	2110363 / 2110360
Power consumption	[kW]	2	2,5	2,5	3,3	3,75	4,5	6	6	7,5	9
Weight	[kg]	1,2	1,3	1,3	1,7	2	2	2	2	2 / 2,3	2 / 2,3
Extension length L/L1	[mm]	- / 380	- / 405	- / 405	325 / -	- / 450	- / 500	- / 520	- / 520	575 / 685	605 / 690
Electrical connection		1/N/PE ~ 230V/50Hz	1/N/PE ~ 230V/50Hz	1/N/PE ~ 230V/50Hz	3/N/PE ~ 400V/50Hz, Δ	3/N/PE ~ 400V/50Hz, Δ	3/N/PE ~ 400V/50Hz, Δ	3/N/PE ~ 400V/50Hz, Δ	3/N/PE ~ 400V/50Hz, Δ	3/N/PE ~ 400V/50Hz, Δ	3/N/PE ~ 400V/50Hz, Δ
Recomm.circuit breaker value	[A]	16	16	16	3 x 10	3 x 10	3 x 10	3 x 16	3 x 16	3 x 16	3 x 20
Degree of protection		IP44									
Scale of set temperature	[°C]	5-74									
Heat. time approx. 150 l 10-60°C	[h]	4,5	4	4	2,7	2,3	2	1,5	1,5	1,3	1

Types TJ 6/4"-2 and TJ 6/4"-2,5 include new flexible supply cable in the socket.

Extension lengths are in a tolerance of ± 10 mm.

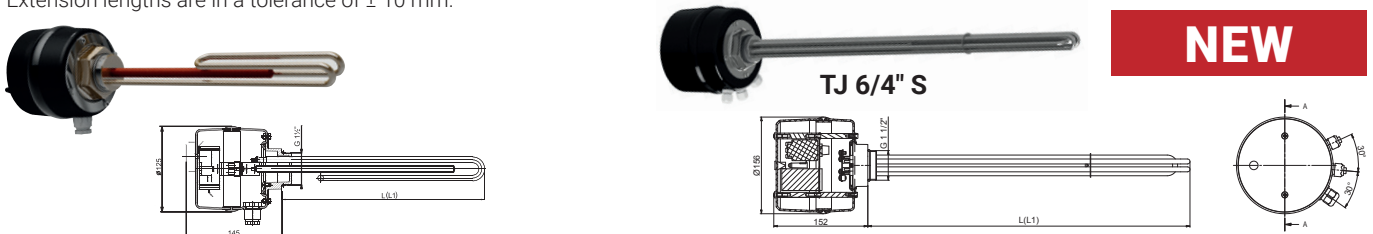

FLANGED ELECTRICAL HEATING UNITS OF THE R, SE SERIES

Type		REU 18-2,5	RDU 18-2,5	RDU 18-3	RDU 18-3,8	RDU 18-5	RDU 18-6	RDU 18-7,5	RDU 18-10	RDU 18-12	RDU 18-15	SE 377	SE 378	
Order number		100541551	100541560	100541561	100541562	100541563	100541564	100541570	100541571	100541580	100541581	100541517	100541511	
Power consumption	[kW]	2,5	2,5	3	3,8	5	6	7,5	10	12	15	8-11-16	9,5-12,7-19	
Weight	[kg]	3	3,3	3,4	3,5	3,5	3,5	3,7	4	4	4,2	8	11,5	
Extension length	[mm]	450									530	630	610	740
Electrical connection		1/N/PE ~ 230V/50Hz	3/N/PE ~ 400V/50Hz, Δ	3/N/PE ~ 400V/50Hz, Δ	3/N/PE ~ 400V/50Hz, Δ	3/N/PE ~ 400V/50Hz, Δ	3/N/PE ~ 400V/50Hz, Δ	3/N/PE ~ 400V/50Hz, Δ	3/N/PE ~ 400V/50Hz, Δ	3/N/PE ~ 400V/50Hz, Δ	3/N/PE ~ 400V/50Hz, Δ	3/N/PE ~ 400V/50Hz, Δ	3/N/PE ~ 400V/50Hz, Δ	
Recomm.circuit breaker value	[A]	16	3 x 6	3 x 6	3 x 10	3 x 10	3 x 16	3 x 16	3 x 20	3 x 20	3 x 25	3 x 25	3 x 32	
Degree of protection		IPX4										IP20		
Heat. time approx. 300 l 10-60°C	[h]	8	8	6	5	4	3	2,5	2	1,5	1,3	2-2-1,3	2-1,5-1	

Extension lengths are in a tolerance of ± 10 mm.



FLANGED ELECTRICAL HEATING UNITS WITH CERAMIC BODY OF THE TPK SERIES

Type		TPK 150-8/2,2	TPK 168-8/2,2	TPK 210-12/2,2	TPK 210-12/3-6	TPK 210-12/6,6	TPK 210-12/5-9	TPK 210-12/12	
Order number		2110409	2110055	2110053	2110050	2110410	2110051	2110414	
Power consumption	[kW]	2,2	2,2	2,2	3-4-6*	6,6	5-7-9*	12	
Weight	[kg]	4,2	4,2	6,6	12	13	13,6	14	
Extension length	[mm]	400	400	440	440	440	550	550	
Electrical connection		1/N/PE ~ 230V/50Hz	1/N/PE ~ 230V/50Hz	1/N/PE ~ 230V/50Hz	1/N/PE ~ 230V/50Hz, 3/N/PE ~ 400V/50Hz, Δ	3 x 230V/50Hz, Δ	3/N/PE ~ 400V/50Hz, Δ	3/N/PE ~ 400V/50Hz, Δ	
Recomm. circuit breaker value	[A]	16	16	16	20/3 x 16	3 x 16	3 x 20	3 x 25	
Degree of protection		IP42							
Scale of set temperature	[°C]	5-74							

* - according to connection method

Extension lengths are in a tolerance of ± 10 mm.



ACCESSORY TABLES

MOUNTING OPTIONS FOR FLANGED ELECTRICAL HEATING UNITS OF THE R SERIES

Type	REU 18-2,5	RDU 18-2,5	RDU 18-3	RDU 18-3,8	RDU 18-5	RDU 18-6	RDW 18-7,5	RDW 18-10	RSW 18-12	RSW 18-15
NAD 500 v1	●	●	●	●	●	●	●	●	●	-
NAD 750 v1	●	●	●	●	●	●	●	●	●	●
NAD 1000 v1	●	●	●	●	●	●	●	●	●	●
NAD 500 v3	●	●	●	●	●	●	●	●	●	-
NAD 750 v3	●	●	●	●	●	●	●	●	●	●
NAD 1000 v3	●	●	●	●	●	●	●	●	●	●
NAD 500 v4	●	●	●	●	●	●	●	●	-	-
NAD 750 v4	●	●	●	●	●	●	●	●	●	-
NAD 1000 v4	●	●	●	●	●	●	●	●	●	●
NAD 500 v5	●	●	●	●	●	●	●	●	-	-
NAD 750 v5	●	●	●	●	●	●	●	●	●	-
NAD 1000 v5	●	●	●	●	●	●	●	●	●	●
NADO 500/140 v1	●	●	●	●	●	●	●	●	●	-
NADO 750/140 v1	●	●	●	●	●	●	●	●	●	●
NADO 1000/140 v1	●	●	●	●	●	●	●	●	●	●
NADO 500/200 v1	●	●	●	●	●	●	●	●	●	-
NADO 750/200 v1	●	●	●	●	●	●	●	●	●	●
NADO 1000/200 v1	●	●	●	●	●	●	●	●	●	●
NADO 500/140 v2	●	●	●	●	●	●	●	●	-	-
NADO 750/140 v2	●	●	●	●	●	●	●	●	●	-
NADO 1000/140 v2	●	●	●	●	●	●	●	●	●	●
NADO 500/100 v3	●	●	●	●	●	●	●	●	-	-
NADO 750/100 v3	●	●	●	●	●	●	●	●	●	-
NADO 1000/100 v3	●	●	●	●	●	●	●	●	●	●
NADO 300/20 v11	●	●	●	●	●	●	●	●	-	-
NADO 400/20 v11	●	●	●	●	●	●	●	●	-	-
NADO 750/25 v11	●	●	●	●	●	●	●	●	●	-
NADO 1000/25 v11	●	●	●	●	●	●	●	●	●	●

- can only be fitted with the 210/150 reduction flange
 - cannot be fitted

MOUNTING OPTIONS FOR FLANGED ELECTRICAL HEATING UNITS OF THE TPK SERIES

Type	TPK 210-12/2,2 kW	TPK 210-12/3-6 kW	TPK 210-12/6,6 kW	TPK 210-12/5-9 kW	TPK 210-12/12 kW
NAD 500 v1	▲	▲	▲	▲	▲
NAD 750 v1	▲	▲	▲	▲	▲
NAD 1000 v1	▲	▲	▲	▲	▲
NAD 500 v3	▲	▲	▲	▲	▲
NAD 750 v3	▲	▲	▲	▲	▲
NAD 1000 v3	▲	▲	▲	▲	▲
NAD 500 v4	▲	▲	▲	-	-
NAD 750 v4	▲	▲	▲	▲	▲
NAD 1000 v4	▲	▲	▲	▲	▲
NAD 500 v5	▲	▲	▲	-	-
NAD 750 v5	▲	▲	▲	▲	▲
NAD 1000 v5	▲	▲	▲	▲	▲
NADO 500/140 v1	▲	▲	▲	▲	▲
NADO 750/140 v1	▲	▲	▲	▲	▲
NADO 1000/140 v1	▲	▲	▲	▲	▲
NADO 500/200 v1	▲	▲	▲	▲	▲
NADO 750/200 v1	▲	▲	▲	▲	▲
NADO 1000/200 v1	▲	▲	▲	▲	▲
NADO 500/140 v2	▲	▲	▲	-	-
NADO 750/140 v2	▲	▲	▲	▲	▲
NADO 1000/140 v2	▲	▲	▲	▲	▲
NADO 500/100 v3	▲	▲	▲	-	-
NADO 750/100 v3	▲	▲	▲	▲	▲
NADO 1000/100 v3	▲	▲	▲	▲	▲
NADO 300/20 v11	▲	▲	▲	-	-
NADO 400/20 v11	▲	▲	▲	-	-
NADO 750/25 v11	▲	▲	▲	▲	▲
NADO 1000/25 v11	▲	▲	▲	▲	▲

- ▲ can be fitted
 - cannot be fitted

ACCESSORY TABLES

MOUNTING OPTIONS FOR SCREW-TYPE ELECTRICAL HEATING UNITS OF THE TJ SERIES

Type	TJ 6/4" - 2*	TJ 6/4" - 2,5*	TJ 6/4" S - 2,5*	TJ 6/4" - 3,3	TJ 6/4" - 3,75*	TJ 6/4" - 4,5*	TJ 6/4" - 6*	TJ 6/4" S - 6*	TJ 6/4" - 7,5	TJ 6/4" - 7,5*	TJ 6/4" - 9	TJ 6/4" - 9*
NAD 50 v1	-	-	-	▲	-	-	-	-	-	-	-	-
NAD 100 v1	▲	▲	▲	▲	▲	▲	▲	▲	-	-	-	-
NAD 250 v1	▲	▲	▲	▲	▲	▲	▲	▲	-	-	-	-
NAD 500 v1	▲	▲	▲	▲	▲	▲	▲	▲	▲	-	▲	-
NAD 750 v1	▲	▲	▲	▲	▲	▲	▲	▲	▲	▲	▲	▲
NAD 1000 v1	▲	▲	▲	▲	▲	▲	▲	▲	▲	▲	▲	▲
NAD 500 v2	▲	▲	▲	▲	▲	▲	▲	▲	▲	-	▲	-
NAD 750 v2	▲	▲	▲	▲	▲	▲	▲	▲	▲	▲	▲	▲
NAD 1000 v2	▲	▲	▲	▲	▲	▲	▲	▲	▲	▲	▲	▲
NAD 300 v3	▲	▲	▲	▲	▲	▲	▲	▲	▲	-	▲	-
NAD 500 v3	▲	▲	▲	▲	▲	▲	▲	▲	▲	-	▲	-
NAD 750 v3	▲	▲	▲	▲	▲	▲	▲	▲	▲	▲	▲	▲
NAD 1000 v3	▲	▲	▲	▲	▲	▲	▲	▲	▲	▲	▲	▲
NADS 800 v3	▲	▲	▲	▲	▲	▲	▲	▲	▲	▲	▲	▲
NADS 900 v3	▲	▲	▲	▲	▲	▲	▲	▲	▲	▲	▲	▲
NAD 500 v4	▲	▲	▲	▲	▲	▲	▲	▲	▲	-	▲	-
NAD 750 v4	▲	▲	▲	▲	▲	▲	▲	▲	▲	▲	▲	▲
NAD 1000 v4	▲	▲	▲	▲	▲	▲	▲	▲	▲	▲	▲	▲
NAD 500 v5	▲	▲	▲	▲	▲	▲	▲	▲	▲	-	▲	-
NAD 750 v5	▲	▲	▲	▲	▲	▲	▲	▲	▲	▲	▲	▲
NAD 1000 v5	▲	▲	▲	▲	▲	▲	▲	▲	▲	▲	▲	▲
NADO 500/140 v1	▲	▲	▲	▲	▲	▲	▲	▲	▲	-	▲	-
NADO 750/140 v1	▲	▲	▲	▲	▲	▲	▲	▲	▲	▲	▲	▲
NADO 1000/140 v1	▲	▲	▲	▲	▲	▲	▲	▲	▲	▲	▲	▲
NADO 500/300 v1	▲	▲	▲	▲	▲	▲	▲	▲	▲	▲	▲	▲
NADO 750/250 v1	▲	▲	▲	▲	▲	▲	▲	▲	▲	▲	▲	▲
NADOS 800/140 v1	▲	▲	▲	▲	▲	▲	▲	▲	▲	▲	▲	▲
NADOS 900/140 v1	▲	▲	▲	▲	▲	▲	▲	▲	▲	▲	▲	▲
NADO 500/140 v2	▲	▲	▲	▲	▲	▲	▲	▲	▲	-	▲	-
NADO 750/140 v2	▲	▲	▲	▲	▲	▲	▲	▲	▲	▲	▲	▲
NADO 1000/140 v2	▲	▲	▲	▲	▲	▲	▲	▲	▲	▲	▲	▲
NADOS 800/140 v2	▲	▲	▲	▲	▲	▲	▲	▲	▲	▲	▲	▲
NADOS 900/140 v2	▲	▲	▲	▲	▲	▲	▲	▲	▲	▲	▲	▲
NADO 300/20 v6	▲	▲	▲	-	▲	▲	-	-	-	-	-	-
NADO 500/25 v6	▲	▲	▲	-	▲	▲	▲	▲	-	-	-	-
NADO 750/35 v6	▲	▲	▲	-	▲	▲	▲	▲	-	-	-	-
NADO 1000/45 v6	▲	▲	▲	-	▲	▲	▲	▲	-	-	-	-
NADO 500/200 v7	▲	▲	▲	-	▲	▲	▲	▲	-	-	-	-
NADO 750/200 v7	▲	▲	▲	-	▲	▲	▲	▲	-	-	-	-
NADO 1000/200 v7	▲	▲	▲	-	▲	▲	▲	▲	-	-	-	-
NADO 800/35 v9	▲	▲	▲	-	▲	▲	▲	▲	-	-	-	-
NADO 1000/35 v9	▲	▲	▲	-	▲	▲	▲	▲	-	-	-	-
NADO 300/20 v11	▲	▲	▲	▲	▲	▲	▲	▲	-	-	-	-
NADO 400/20 v11	▲	▲	▲	▲	▲	▲	▲	▲	-	-	-	-
NADO 750/25 v11	▲	▲	▲	▲	▲	▲	▲	▲	▲	▲	▲	▲
NADO 1000/25 v11	▲	▲	▲	▲	▲	▲	▲	▲	▲	▲	▲	▲
UKV 300	▲	▲	▲	▲	▲	▲	▲	▲	▲	-	-	-
UKV 500	▲	▲	▲	▲	▲	▲	▲	▲	▲	-	▲	-

* TJ 6/4" with extended cold side

- ▲ can be fitted
- cannot be fitted

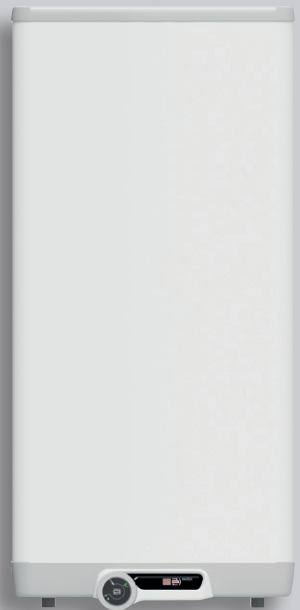
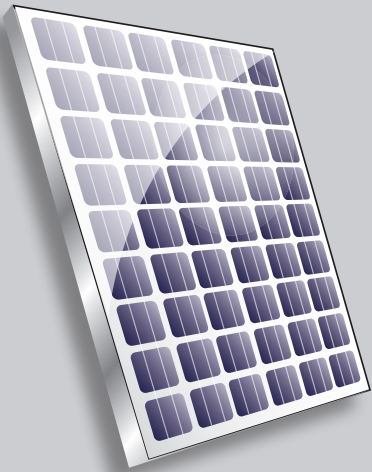

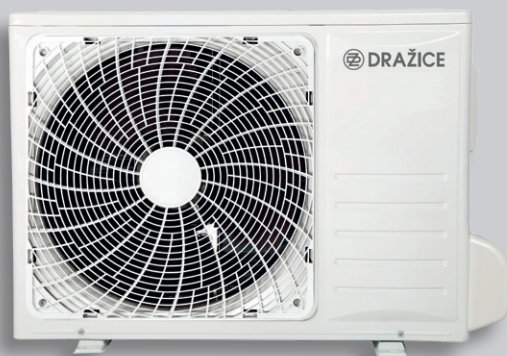

ANOTHER ASSORTMENT

PHOTOVOLTAIC
WATER HEATERS

Technology for direct connection of photovoltaic panels to water heating.

The use of photovoltaic panels for water heating is an ecological production of electricity, which is fully consumed directly by the manufacturer. No connection permissions are required, and no additional devices need to be purchased.

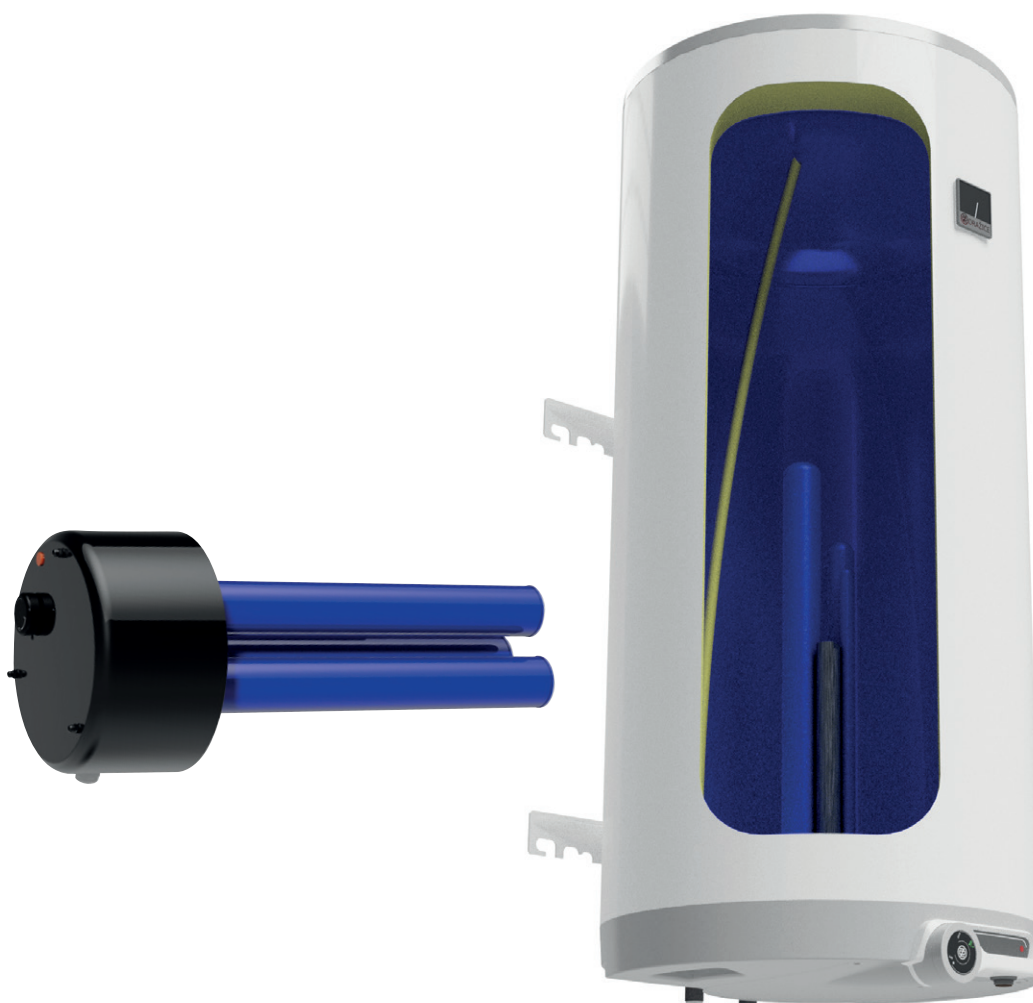

More information can be found at www.dzd-fv.cz/en

There is over 380 types of water heaters in product portfolio of Dražice.
Volume from 5l up to 1000l

Standart assortment - following the type of installation

- wall-mounted – vertically or horizontally
- floor-standing

Other assortment - following the type of heat source

- electric
- combined
- indirect



More information can be found at www.dzd.cz/en/ohrivace-a-zasobniky-teple-vody

SPLIT AIR is an air conditioner with one indoor unit designed for flats, family houses, offices or smaller facilities.

The air conditioner consists of an outdoor unit, one indoor unit and a smart remote controller.

All three performance variants of the AIR air conditioner offer cooling, heating, a fan and drying functions.

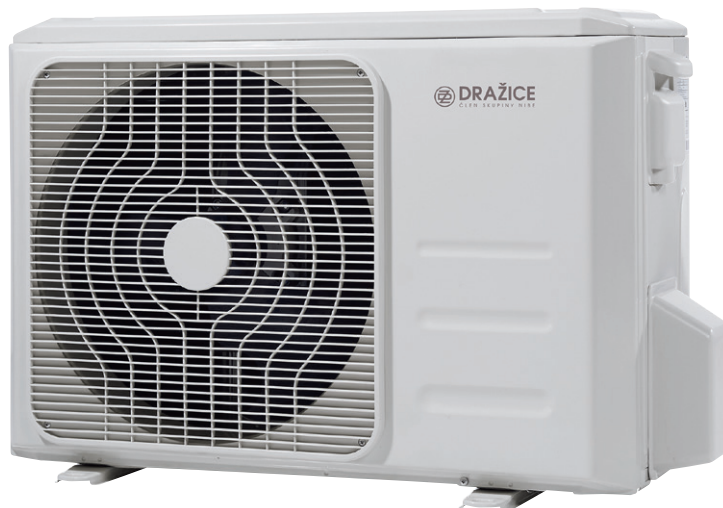

The Multisplit AIR PLUS air conditioners are designed for systems with a requirement for more indoor units.

In this solution, one suitably dimensioned outdoor unit is supplemented by two to four indoor units of identical or different outputs so that the requirements of the project are optimally met.

By combining three types of outdoor units and four types of indoor units, practically any configuration of cooling and heating systems can be achieved exactly according to your needs.

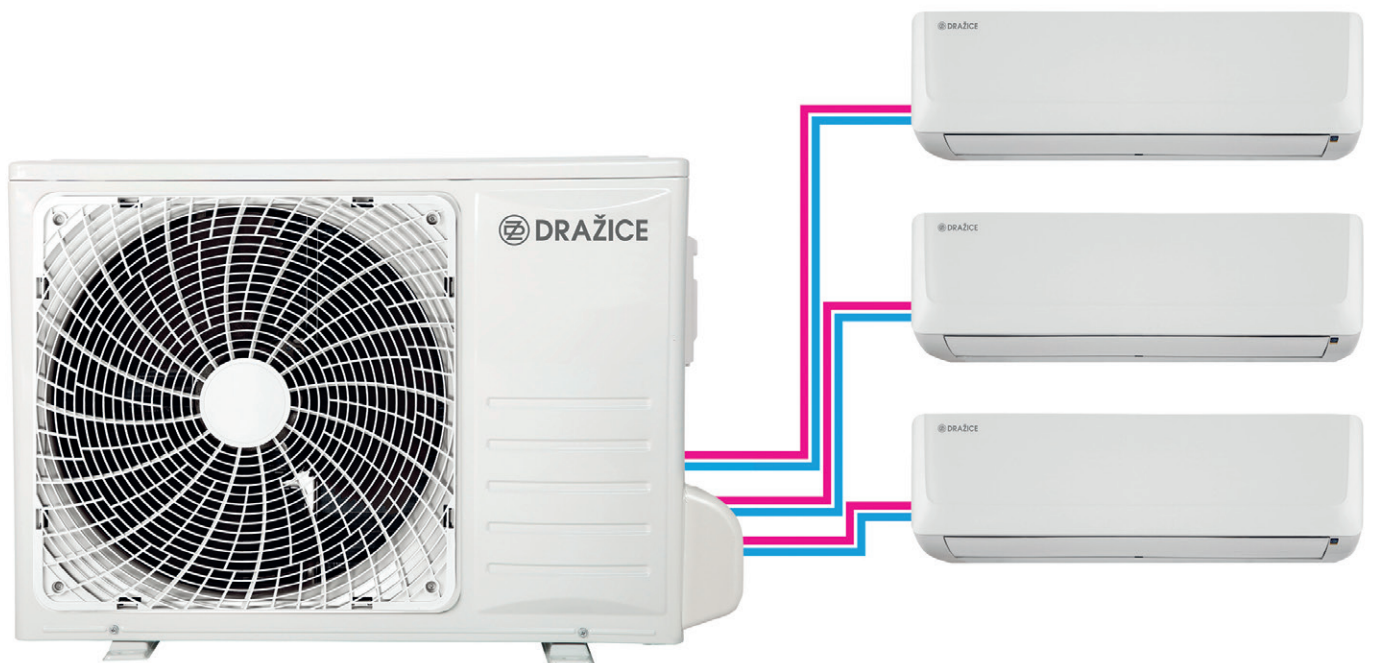

DRUŽSTEVNÍ ZÁVODY DRAŽICE-STROJÍRNA s.r.o.

Dražice 69, 294 71 Benátky nad Jizerou
Czech republic

tel.: +420/326 370 961

e-mail: export@dzd.cz

www.dzd.cz/en

www.dzd-fv.cz/en



PROUD
PARTNER OF

