

# Operation and Installation Manual



## Built-in Electric Flange Heating Unit

**REU 18 - 2,5**  
**RDU 18 - 2,5**  
**RDU 18 - 3**  
**RDU 18 - 3,8**  
**RDU 18 - 5**  
**RDU 18 - 6**  
**RDW/RDU 18 - 7,5**  
**RDW/RDU 18 - 10**  
**RSW 18 - 12**  
**RSW 18 - 15**  
**SE 377**  
**SE 378**

**Družstevní závody Dražice-strojírna s.r.o.**

Dražice 69

294 71 Benátky nad Jizerou

tel.: +420- 326 370 911

fax.: +420- 326 370 980

e-mail: [dzd@dzd.cz](mailto:dzd@dzd.cz)

[www.dzd.cz](http://www.dzd.cz)

# Read carefully the below instructions prior to the installation of the heating unit!

Dear Customers!

The “R” heating element series by Austria Email AG (Austria) and the “SE” series of heating elements by Winkelmann GmbH, Stahl-Behälter-Technik (Germany) are manufactured and tested accordingly with the valid ÖVE or VDE safety regulations.

Their installation and putting into operation may only be implemented by assembly companies, following this manual. In this manual, you can find all important instructions necessary for proper installation and operation. Despite that, have the element installation, operation, and functions demonstrated and explained.

Naturally, our department is at your service: *Service and Sales Dept.*

Contents	Page
1. Function.....	3
2. Energy saving.....	3
3. Operation and temperature setting.....	3
4. Operation preconditions.....	3
5. Assembly and Safety Instructions.....	3
5.1 General Instructions.....	3
5.2 Installation Scheme.....	5
5.3 Heating Unit Assembly.....	6
5.4 Anti-corrosion Protection Instructions.....	6
5.5 Accumulator Connection to the Pressurized Water Main.....	6
5.6 Electrical Connection.....	7
5.7 First putting into operation.....	9
6. Inspection, Care, Maintenance.....	10
7. Functional Defects.....	10
8. Technical Data.....	10



## 1. Function

The R and SE series built-in electric flange heating units as main heaters for electric boilers are self-servicing. If calcium rich water is used, scale needs to be removed from the heating element in given time intervals.

The user may set a temperature on the thermostat. The element is turned on automatically; after reaching set water temperature, it is turned off. If the temperature drops (e.g. either by water consumption or natural cooling), the unit is turned on and heated to the pre-set temperature.

## 2. Energy saving

Low water temperature in the boiler proves to be especially economic. Therefore the temperature should be set to be adequate for intended hot water consumption, not higher. This helps to save electricity and prevents lime sediment occurrence.

## 3. Operation and temperature setting

The temperature of water in the heater can be adjusted as needed by the thermostat, either continuously or in three steps as indicated. This allows energetically economic operation. To set the temperature, 3 main marked symbols are used:

- Accumulator freezing protection;
- Approx. 40 °C, water temperature for washing hands;
- Approx. 65 °C, hot water – to prevent scalding, this degree is recommended as it is the economic operation with minimum energy loss and minimum scale occurrence;

**Warning:** When the thermostat button is in the utmost left position, this is not the zero position nor is the heating turned off.  
During day mode operation, the thermostat should not be set to temperatures above 65 °C.

## 4. Operation preconditions

The connection of a built-in electric flange unit must follow the data on the plate (operation pressure, heating time, el. voltage). **Connecting to the electrics must follow the scheme on the inside of the protective cover.**

Aside from the electric regulations, the conditions of local distribution and water supply plants, as well as assembly and operation conditions, must be followed. If the water is really hard, we recommend installation of water treatment filters preventing the scale occurrence.

These heating elements are suitable for enamelled accumulators, double casing tanks, or accumulators coated with either plastic or zinc; they are also suitable for ribbed exchangers. Combination with chromium–nickel vessels is problematic, and therefore not recommended (see par. 5.3). All elements are suitable for heating drinkable and heating water with operating pressure within 10 bar.

## 5. Assembly and Safety Instructions

### 5.1 General Instructions

During operation, both the heating element and the anode rod must be under water. Necessary thermal flow of heated water must not be prevented. The heating unit is equipped with a safety fuse preventing further water heating at maximum temperature of 120 °C. It is therefore necessary to select suitable connecting components (pipelines, safety valve combination) that, in case of thermostat defect, resist the max. temperature of 120 °C.

**Both the assembly and installation must be implemented by authorised people only.**

**Both electric and water installation must follow and meet requirements and regulations relevant in the country of use.**

## Position of installation of elements of series: R, SE

Correct

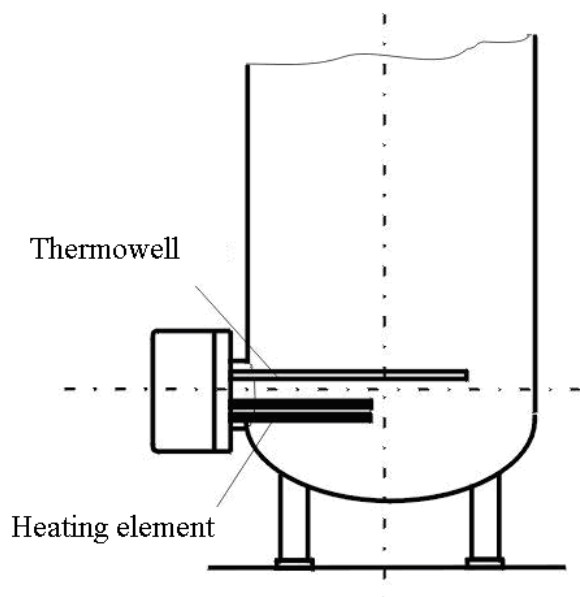

Faulty

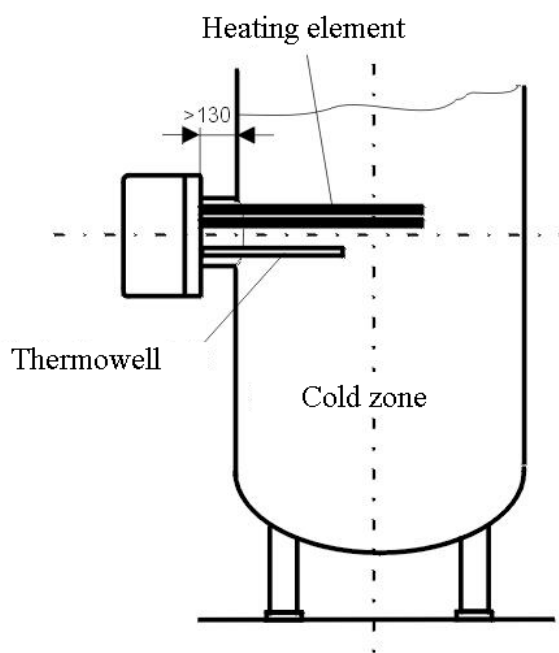

Too long flange welded too high.  
Thermowell under the heating element.

## Vertical installation from the bottom

Přípustná jen u typů R, SE

Correct

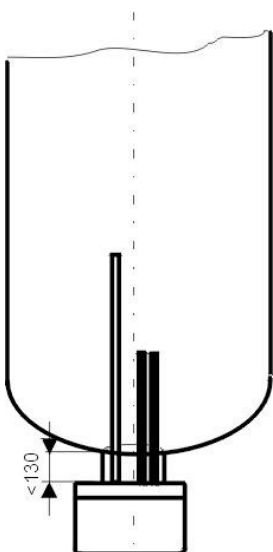

Faulty

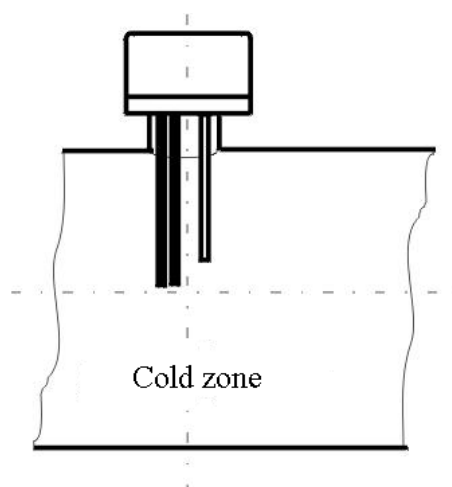

The unit built in too high and in reversed position (the protective guard is up).

The flange rim must not exceed 130 mm, so that the temperature sensor and the element reach into the tank deep enough. Correct position of a built-in element assures even heating of the tank contents. In front of the flange, a +100 mm free space must be left for the assembly.

Scale occurrence lowers functionality; it is therefore necessary, especially with hard water, to take the following measures: Select proper temperature setting; install device lowering water hardness; regular removal of boiler scale.

**Damage to the heating element due to calcareous sediments is not accepted by the manufacturer as a reason for complaint.**

## 5.2 Installation Scheme

The number of elements differs according to type line.

**For the R, SE type series**

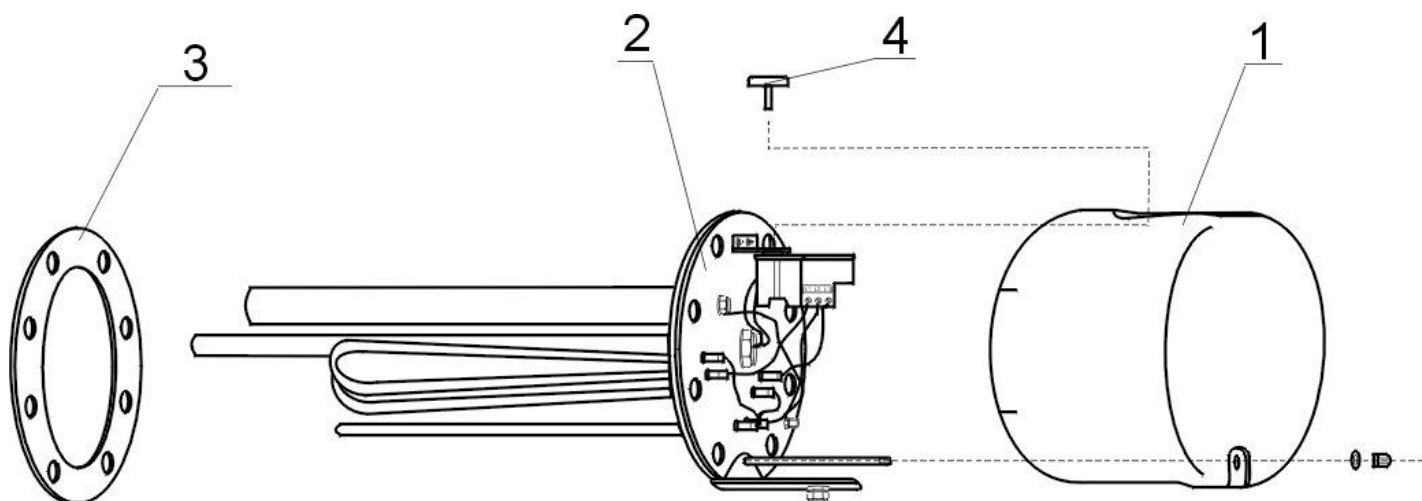

**Adequate flanges:**

**For all types  
R...18...(  $\varnothing 180$  )  
8 holes**

**For all types  
SE 377, SE 378 (  $\varnothing 255$  )  
10 holes**

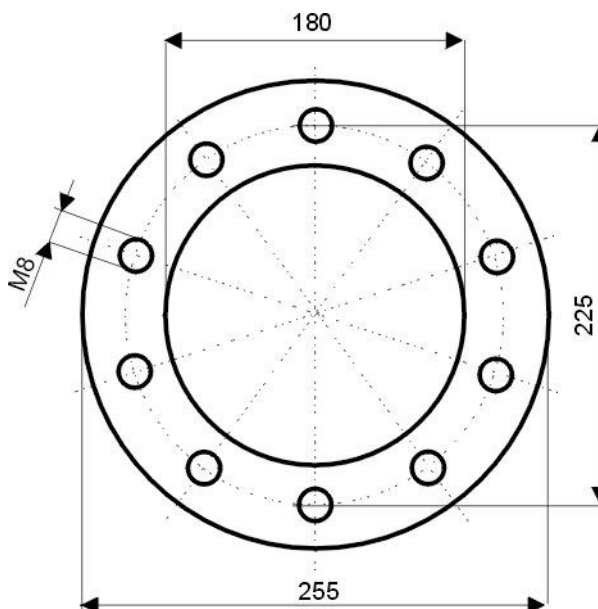
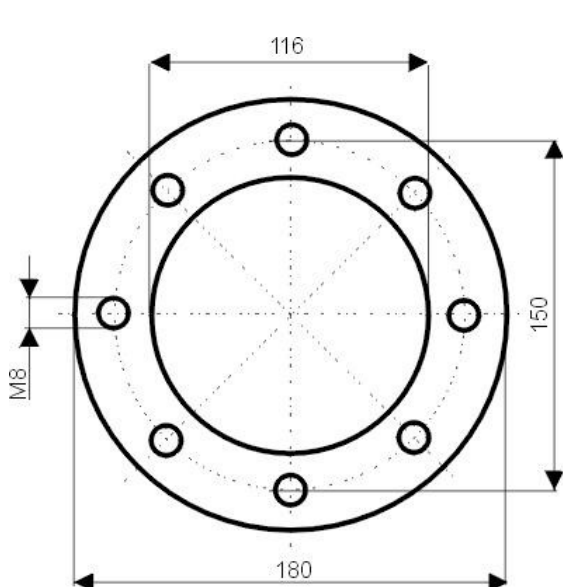

### 5.3 Heating Unit Assembly

Aside from the installation regulations, the conditions of connection resulting from local distribution and water supply plants must be followed:

1. Remove protective cover, position 1;
2. Install heating flange with the seal (position 2.3) into the tank (Fig. 3). The thermowell must always be above the heating element well;
3. Fit the heating flange (position 2) using M8 screws (max. tightening torque 22 Nm), tightened crosswise; Screwing the heating element must be tested and tightened with a 2 – 3 Nm tightening torque;
4. Implement electric connection following the scheme (see point 5.6). **Warning** – do not forget to connect the guard wire;
5. Fit the protective cover and tighten with a nut, fit the control wheel of the thermostat;
6. **Put into operation only if water is in the accumulator;**

**Heating element assembly and its initial operation can only be implemented by an expert, who takes responsibility for proper implementation and equipment.**

### 5.4 Anti-corrosion Protection Instructions

Heating unit maintenance involves checking and exchanging of the anode rod that is only contained in outputs from 2.5 to 6 kW.

Magnesium anode sets the electric potential inside the tank to a level that limits boiler tank corrosion. Theoretically, its lifetime is calculated to two years of operation; however, it changes based on water hardness and chemical composition at the place of use. Anode rod check and possible replacement is recommended every two years of operation. Based on anode wear, set the time of the next check. We recommend you do not underestimate the importance of this additional protection of the boiler tank.

#### **Anode rod exchange method:**

1. Turn off the boiler control voltage;
2. Empty the boiler water.

#### **Procedure: Close the water entry valve to the boiler**

##### **Open the hot water valve on the mixing tap**

##### **Open the boiler drain tap**

3. The anode is screwed onto the heating unit
4. Unscrew the anode using adequate wrench
5. Pull the anode out and follow reversed steps to install a new one
6. During the assembly, make sure the ground wire is connected properly; it is essential for proper anode function
7. Fill the boiler with water

### 5.5 Accumulator Connection to the Pressurized Water Main

Accumulator assembly, connection, and use instructions must be followed.

#### **Connection to the Pressure System**

If inadequate and non-functional fittings are used and the operational pressure exceeded, the warranty is cancelled.

Water main connection may only be implemented via a diaphragm safety valve or a diaphragm safety combination. Safety valve combination consists of a closing valve, pressure reducing valve, test valve, backflow valve, overload valve with compensation circulation, and a drain valve. This combination is built in between the cold water inlet and cold water inlet to the reservoir.

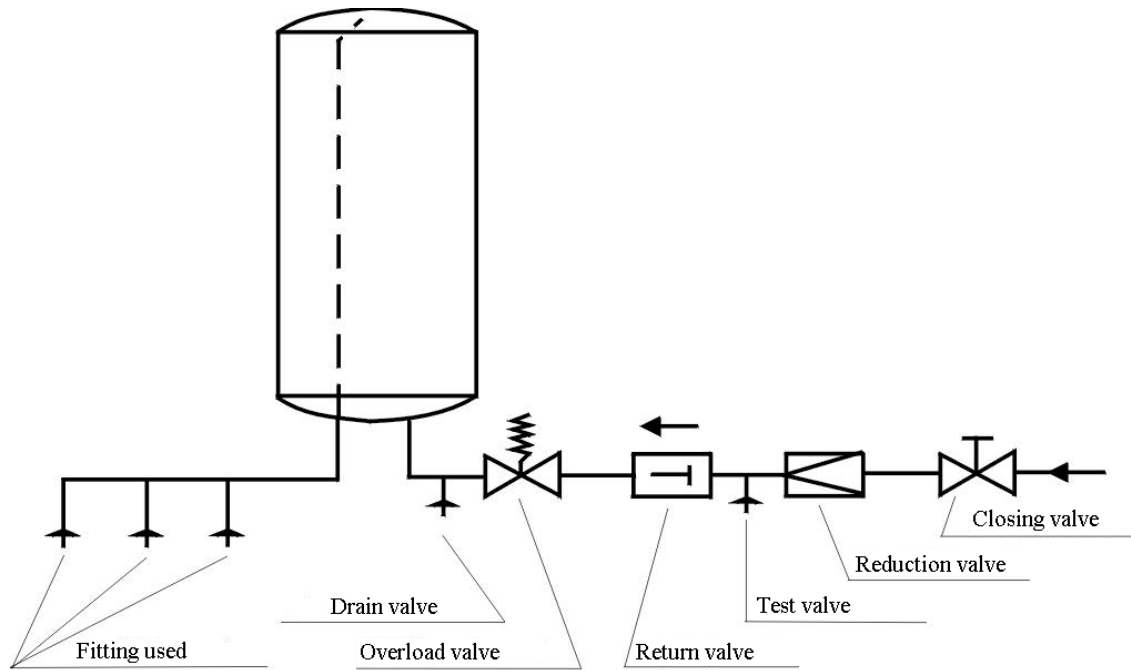

## 5.6 Electrical Connection

**Heating element assembly and its initial operation can only be implemented by an expert, who takes responsibility for proper implementation and equipment.**

**The electrical connection must be implemented based on the attached scheme. The scheme related to a specific type is inside the plastic cover of the heating unit!**

**The network voltage must be respected!**

**All metal parts of the accumulator must meet relevant protective regulations.**

The main must have a multipole switch with a 3 mm contact clearing. All switches must be connected to circuit breakers. The lead in cable must be led into the area of connection via a sealing connector and secured from shifting, wringing, and tearing out by a clamp.

**! Warning! Factory connection must not be changed.**

### **Connection scheme for SE 377, SE 378**

The heating unit allows 3 types of connection.

R= 3,2

Factory connection must not be changed.

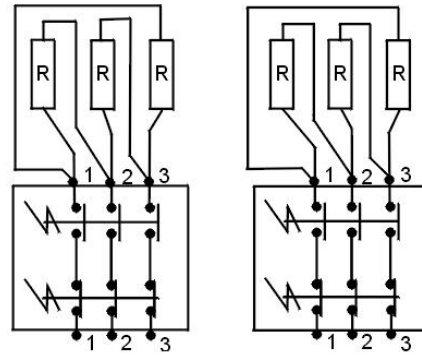

3 PE - N - AC 400V

SE 377 - 8 kW  
SE 378 - 9,5 kW

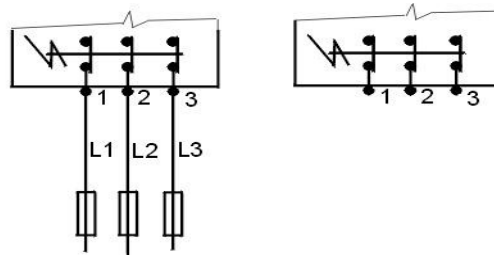

3 PE - N - AC 400V

SE 377 - 11 kW  
SE 378 - 14 kW

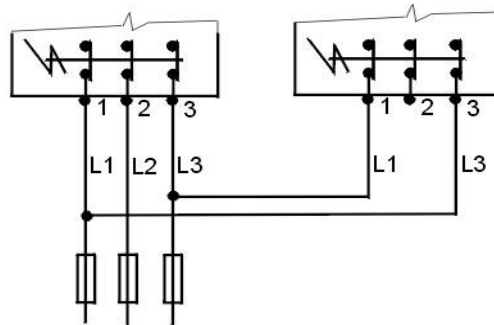

3 PE - N - AC 400V

SE 377 - 16 kW  
SE 378 - 19 kW

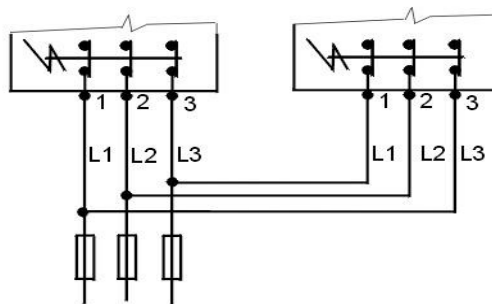



**Connection scheme for REU type – 230 V**

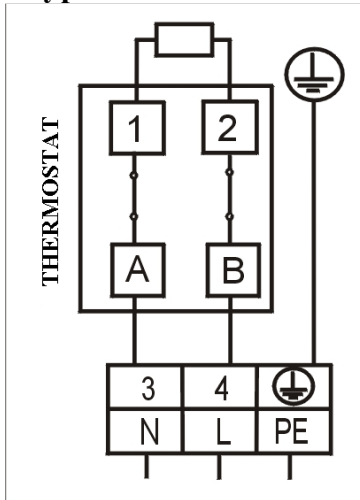

**Connection scheme for RDU & RDW types – 400 V connection**

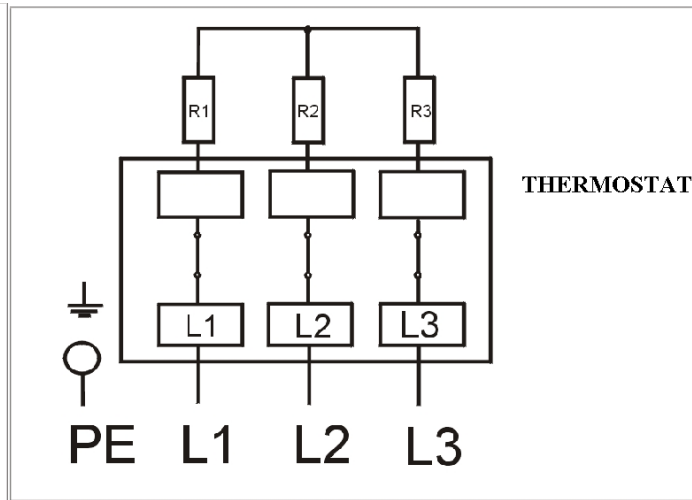

**Connection scheme for RSW 18-12 and RSW 18-15 elements**

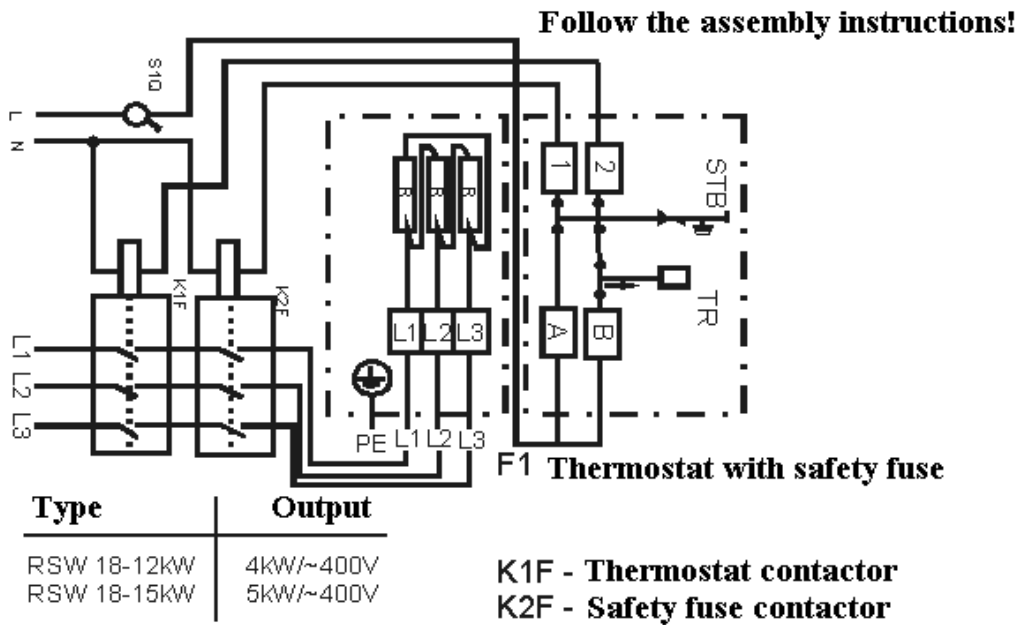

**!! Connection is only possible with a contactor, not directly through the thermostat!**

**5.7 First putting into operation**

Before electric part connection, the accumulator must be filled with water. During the rating, water must drip off the safety valve.

**Warning:** Both the hot water outlet pipe and safety armature parts may be hot.

After heating, the set temperature of consumed water should roughly correspond with temperature shown on the thermometer.

## 6. Inspection, Care, Maintenance

High calcium content water requires the removal of both scale and calcium sediments after one or two years, implemented by an expert worker. Cleaning may be implemented through the flange opening; a new seal must be used during assembly.

Specially enamelled accumulator containers must not get in contact with scale solvents or a lime pump. Eventually, the container must be thoroughly rinsed; its re-heating must follow the method of the first putting into operation.

After two years of operation, it is recommended that an expert checks the functionality of the –in-built magnesium anode. During the maintenance, protective connection of all metal (conductive) parts of the heater must not be damaged or removed. Neither mechanical means causing abrasion nor paint thinners (nitro, tricholor, etc.) can be used for cleaning. It is best to use a wet cloth with couple drops of a neutral cleaning preparation.

## 7. Functional Defects

If the water in the accumulator is not heated, check either the circuit breaker or the fuse and the thermostat settings. In all other cases, do not try to remove the defect yourself. Seek either expert or service help. It does not take much for an expert to remove the defect. When making a repair appointment, report the type and serial number you find on the performance plate of your heating element.

## 8. Technical Data

**Flange diameter 180 mm - REU 18, RDU 18, RDW 18, RSW 18**

**Flange diameter 255 mm - SE 377, SE 378**

REU: Single-phase version for direct connection ~ 230 V

RDU, RDW, RSW, SE: Three-phase version for direct connection 3~400 V

Type	Output	Connection	Element length ( mm )	Weight (kg)
<b>REU 18 - 2,5</b>	2,5	1 PE-N AC 230 V / 50 Hz	450	3
<b>RDU 18 - 2,5</b>	2,5	3 PE-N AC 400 V / 50 Hz	450	3,3
<b>RDU 18 - 3</b>	3	3 PE-N AC 400 V / 50 Hz	450	3,4
<b>RDU 18 - 3,8</b>	3,8	3 PE-N AC 400 V / 50 Hz	450	3,5
<b>RDU 18 - 5</b>	5	3 PE-N AC 400 V / 50 Hz	450	3,5
<b>RDU 18 - 6</b>	6	3 PE-N AC 400 V / 50 Hz	450	3,5
<b>RDW 18 - 7,5</b>	7,5	3 PE-N AC 400 V / 50 Hz	450	3,7
<b>RDW 18 - 10</b>	10	3 PE-N AC 400 V / 50 Hz	450	4
<b>RSW 18 - 12</b>	12	3 PE-N AC 400 V / 50 Hz	530	4
<b>RSW 18 - 15</b>	15	3 PE-N AC 400 V / 50 Hz	630	4,2
<b>SE 377*</b>	8,0-11-16	3 PE-N AC 400 V / 50 Hz	610	8
<b>SE 378*</b>	9,5-14-19	3 PE-N AC 400 V / 50 Hz	750	11,5

\* For 750 and 1000 litre heaters only

Types REU, RDU, RDW and RSW can be with reduction flange used also for 750 and 1000 litre heaters

## Heating time:

Capacity	Flange size in mm	Time of heating from 10°C to 60°C (hours)								
		8	6	5	4	3	2,5	2	1,5	1
300	flange $\phi$ 150	RDU 18-2,5	RDU 18-3	RDU - 3,8	RDU 18-5	RDU 18-6	RDW 18-7,5	RDW 18-10	RSW 18-12	RSW 18-15
400	flange $\phi$ 150	RDU 18-3	RDU - 3,8	RDU 18-5	RDU 18-6	RDW 18-7,5	RDW 18-10	RSW 18-12	RSW 18-15	
500	flange $\phi$ 150	RDU - 3,8	RDU 18-5	RDU 18-6	RDW 18-7,5	RDW 18-10	RSW 18-12	RSW 18-15		

Capacity	Flange size in mm	Time of heating from 10°C to 60°C (hours)							
		8	6	5	4	3	2,5	2	
750	flange $\phi$ 150	RDU 18-6	RDW 18-7,5	RDW 18-10	RSW 18-12	RSW 18-15			
	flange $\phi$ 225		SE 377 - 8	SE 378 - 9,5	SE 377 - 11	SE 378 - 14	SE 377 - 16	SE 378 - 19	
1000	flange $\phi$ 150	RDW 18-7,5	RDW 18-10	RSW 18-12	RSW 18-15				
	flange $\phi$ 225	SE 377 - 8	SE 378 - 9,5	SE 377 - 11	SE 378 - 14	SE 377 - 16	SE 378 - 19		

**Note:** Flange diameter 150 and 225 mm = screw spacing

## Reduction flange

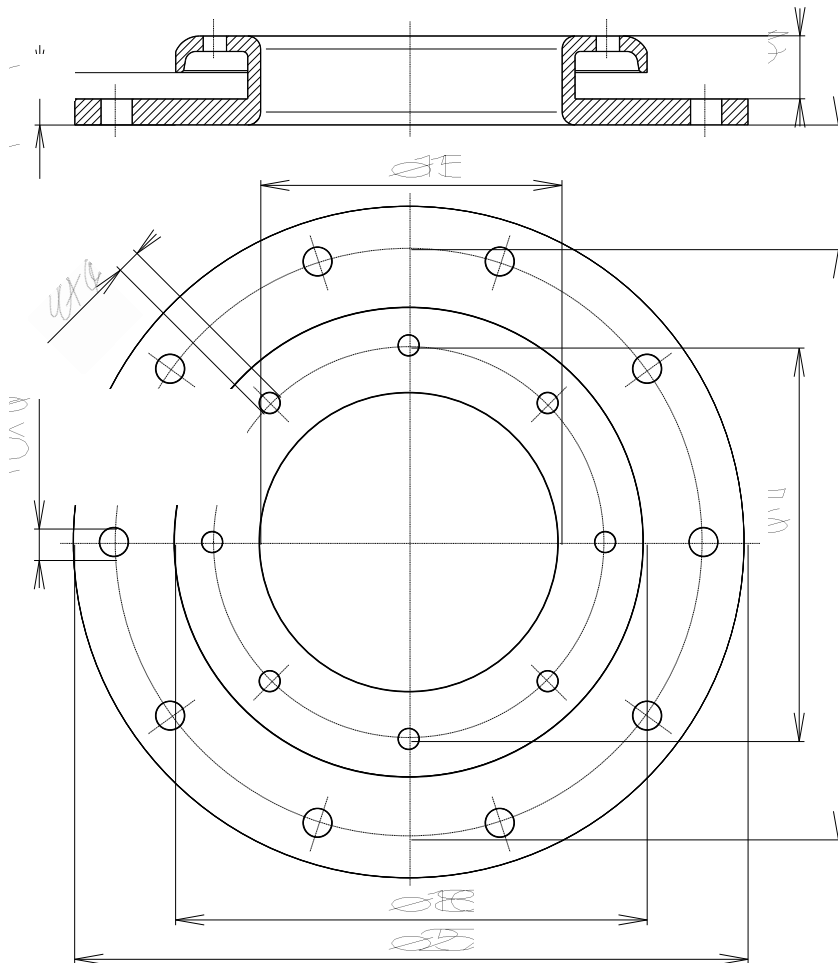

**Disposal of packaging material and functionless product**

A service fee for providing return and recovery of packaging material has been paid for the packaging in which the water heater was delivered pursuant to Act No. 477/2001 Coll., as amended, at EKO-KOM a.s. The client number of the company is F06020274. Take the water boiler packages to a waste disposal place determined by the town. When the operation terminates, disassemble and transport the discarded and unserviceable heater to a waste recycling centre (collecting yard), or contact the manufacturer.



04-2012