

OPERATING AND INSTALLATION MANUAL

Accumulation Tank

NADO 300/20v6



NADO 500/25v6

NADO 750/35v6

NADO 1000/45v6



Družstevní závody Dražice - strojírna s.r.o.
Dražice 69, 294 71 Benátky nad Jizerou
Phone.: +420 /326 370 990
Fax: +420 / 326 370 980
e-mail: prodej@dzd.cz



CONTENTS

1	PRODUCT TECHNICAL SPECIFICATION	4
1.1	FUNCTION DESCRIPTION	4
1.2	DESIGNING THE SIZE AND CONNECTION OF STORAGE TANK TO THR HEATING SYSTEM.....	5
1.3	TECHNICAL PARAMETERS.....	6
2	IMPORTANT NOTICES	7
3	TECHNICAL DESCRIPTION	8
3.1	NADO 500/25v6, 750/35 v6, 1000/45 v6	9
3.2	NADO 300/20v6.....	10

PRIOR TO THE INSTALLATION OF THE TANK, READ CAREFULLY THIS MANUAL!

Dear customer,

The Works Cooperative of Dražice – Machine Plant, Ltd., would like to thank you for your decision to use a product of our brand. The present instructions will introduce you to the use, construction, maintenance and other information regarding electrical water tanks.



The manufacturer reserves the right for engineering modification of the product. The product is designed for permanent contact with drinkable water.

The product is not intended to be controlled by

- a) people (including children) with reduced physical, sensual or mental capacities, or
- b) people with insufficient knowledge and experiences unless supervised by responsible person, or unless properly instructed by such responsible person.

It is recommended to use the product in indoor environment with air temperatures from +2°C to 45°C and a relative humidity up to 80%.

Product's reliability and safety is proven by tests implemented by the Engineering Test Institute in Brno.

Made in the Czech Republic.

Meaning of pictograms used in the Manual



Important information for tank users.



Abiding by the recommendations of the manufacturer serves to ensure trouble-free operation and the long service life of the product.



Caution!

Important notice to be observed.

1 PRODUCT TECHNICAL SPECIFICATION

1.1 FUNCTION DESCRIPTION

Storage tanks serve accumulation of excessive heat from its source. The source may be a solid fuel boiler, heat pump, solar collectors, fireplace inserts, etc. Some types of storage tanks allow combination of connecting even multiple sources.

The NADO type storage tanks serve accumulation of heat in the heating system and allow heating or preheating of HSW (Hot Service Water) in an inner stainless vessel. Incorporation of a storage tank in the heating system with a solid fuel boiler allows an ideal run of a boiler at favourable temperature during the boiler operation. The main benefit lies in the period of optimum operation (i.e. with maximum efficiency) when the excessive unconsumed heat accumulates in the storage tank.

The storage tanks are manufactured in 300, 500, 750 and 1000-litre volumes. The tanks and tubular exchangers are made of steel, without the inner surface treatment, the outer surface of the tank is provided with a protective paint. Individual versions are additionally equipped with a tubular exchanger and a buried stainless exchanger of 20, 25, 35 and 40 litre volumes, and two funnels G1½" mm, with the possibility to install an electric heating element of TJ 6/4" series with an extended cooling compartment. The storage tanks are equipped with a removable 100 mm thick insulation – polyester foam (Symbio) and a lock.

The NADO type enables direct heating of HSW (Hot Service Water) in a stainless exchanger, or its preheating for another water heater. Connection to a boiler usually allows direct HSW heating in an inner stainless exchanger to the desired temperature whilst, on the contrary, connection to solar collectors or heat pump only preheats HSW and another, e.g. electric, heater has to be used, in order to complete heating of the water to the desired temperature, or final electric reheat has to be fitted in the storage tank which is enabled by a TJ 6/4" series electric heating unit with an extended compartment of up to 6 kW output.

1.2 DESIGNING THE SIZE AND CONNECTION OF STORAGE TANK TO THR HEATING SYSTEM

An ideal size of the storage tank is designed by a design engineer, or a person sufficiently qualified to design heating systems.

Product assembly must be implemented by an authorised person (confirmed in the warranty certificate).



When putting into operation, water has to be filled first into the inner stainless HSW exchanger and the operating pressure inside it has to be kept, only then heating water can be filled into the outer storage tank, otherwise the product may get damaged!

The manufacturer explicitly emphasises the necessity of being particular in testing the tightness of the heating circuit (radiators, piping joints, floor heating, etc.) with the connection of the storage tank. No pressure grow above the maximum operating pressure of 0,3 MPa in the storage tank heating water compartment may occur, if the heating system is pressurised to higher than the maximum operating pressure, the inner stainless exchanger may get permanently damaged!



No stop fitting can be put between the security fitting of the heating circuit and the storage tank!!!

1.3 TECHNICAL PARAMETERS

	NADO 300/20 v6	NADO 500/25 v6	NADO 750/35 v6	NADO 1000/45 v6
Storage tank capacity [l]	320	475	772	999
Inner tank capacity [l]	20	23	32	37
Weight [kg]	106	134	165	197
Heating surface of the stainless exchanger [m ²]	4,5	6,25	8,5	10
Heating surface of the exchanger [m ²]	1,6	2,2	2,2	3,3
Maximum pressure [MPa]	0,3	0,3	0,3	0,3
Maximum pressure of stainless exchanger [MPa]	0,6	0,6	0,6	0,6
Maximum pressure of exchanger [MPa]	1	1	1	1
Maximum temperature of water in the tank and exchanger [°C]	90	90	90	90
Amount of hot water at 40°C at water temperature of 53°C in the storage tank /HW flow rate [l/(l/min)]	210 / 10	260 / 10	490 / 10	750 / 10
Amount of hot water at 40°C at water temperature of 80 in the storage tank /HW flow rate [l/(l/min)]	520 / 10	650 / 10	1170 / 10	1450 / 10
Maximum output of el. heating element of TJ 6/4" series [kW]	2 x 4,5	2 x 6	2 x 6	2 x 6
Standing loss [W]	80	91	114	148

Table 1

2 IMPORTANT NOTICES

Connection of internal tank for hot water must comply with CSN 060830, i.e. on cold water inlet is necessary to install a safety valve.



We recommend to start up the heating circle before commissioning and to clean possible dirt caught in the filter and after this the system would be fully functional.



Recommended operating pressure of hot water circle is 0.4 MPa. We recommend installing return valve and an expansion vessel (min. 4 % of hot water in pipeline) on hot water outlet to eliminate back pressure impacts.

The reservoir is possible to use only in compliance with conditions stated on performance plate and with instructions for wiring. It is also necessary to observe terms for connection stipulated by some local electrical and water companies as same as manual for assembling and operation besides statutory accepted national regulations and standards.

Shut down the reservoir cold water intake if you are not using the reservoir for longer than 24 hours or if the object with the heater is without presence of any person.

3 TECHNICAL DESCRIPTION

- 1 Bleeding (heating water outlet)
- 2 Hot water outlet G 1¼"
- 3 Funnel for additional heating element TJ 6/4" with an extended cooling compartment 2x
- 4 Funnel for a thermowell 4x G 1/2"
- 5 Funnel for connecting another heating water source 6x G 1 ¼"
- 6 Inlet into exchanger G 1" (SOLAR)
- 7 Cold water inlet G 1 ¼"
- 8 Outlet from exchanger G 1" (SOLAR)
- 9 Funnel for discharge G 1"
- 10 Steel receptacle
- 11 Exchanger for connecting solar collectors (heat pump)
- 12 Buried stainless exchanger for service water heating by flow

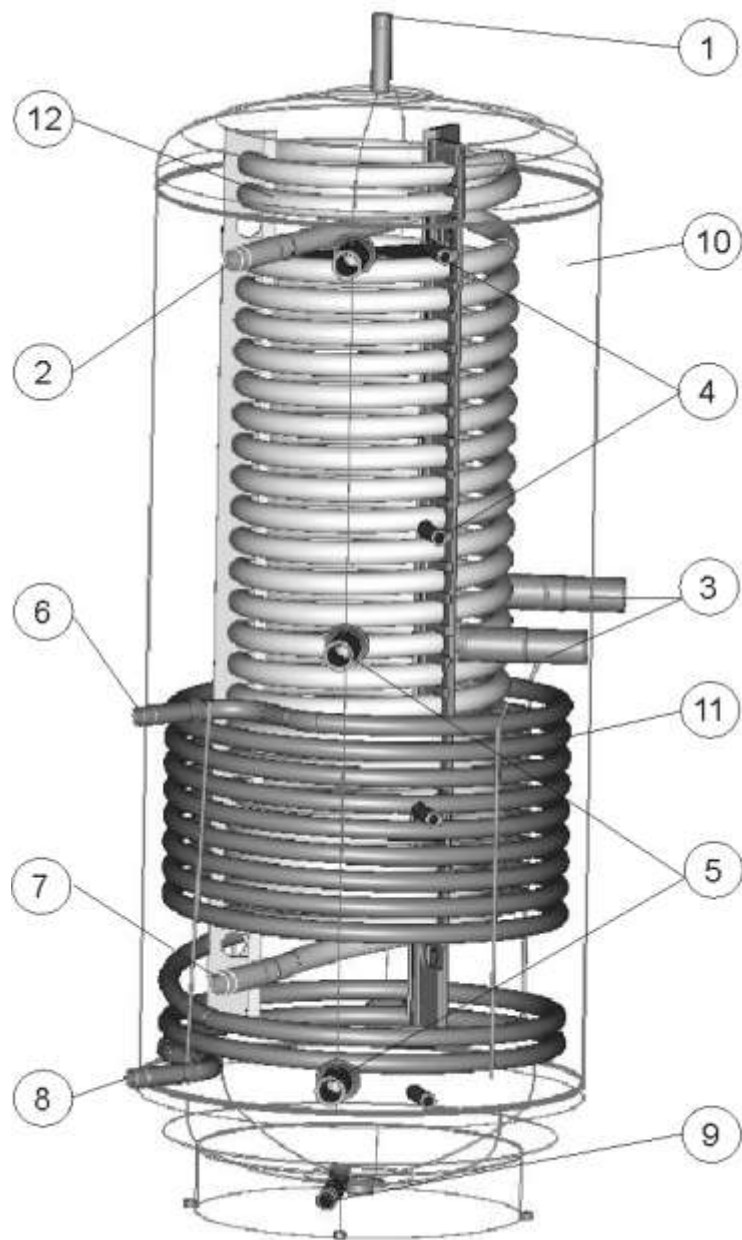

3.1 NADO 500/25v6, 750/35 v6, 1000/45 v6

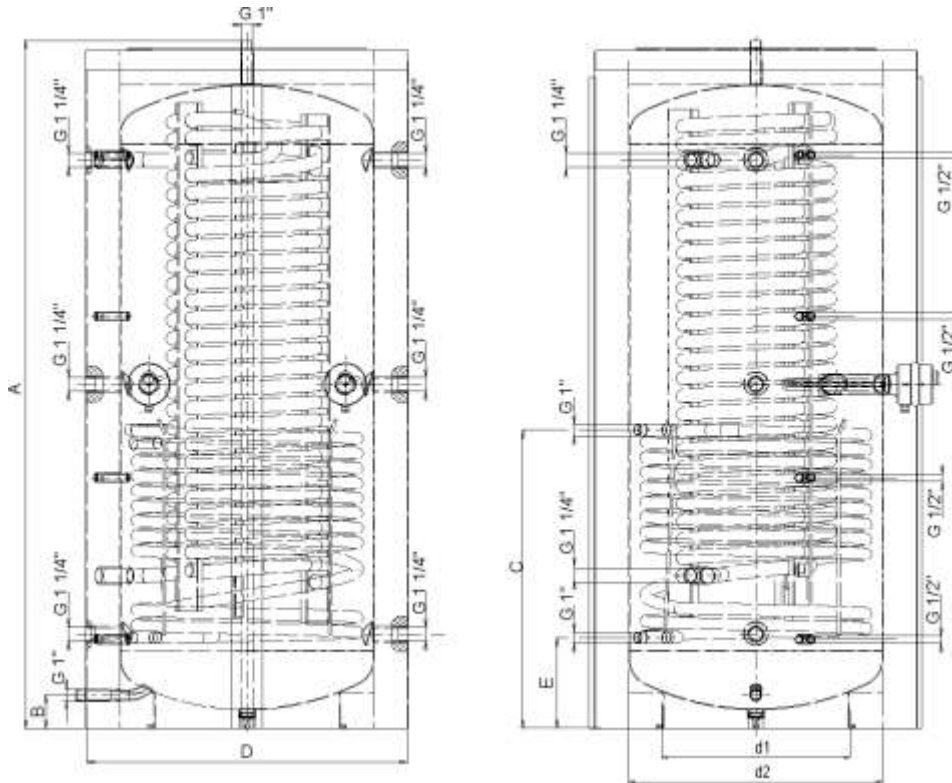

TYPE	NADO 500/25v6	NADO 750/35 v6	NADO 1000/45v6
A	1992	2031	2058
B	90	98	90
C	915	882	1035
D	800	950	1000
d1	440	550	600
d2	600	750	850
E	255	255	282

Thermal insulation: NEODUL

Polyester sheet of 100 mm thickness. It consists of an upper cover, flange cover and hole caps. Insulation is supplied in a separate packaging.

We recommend that the insulation was fitted at room temperature.

At temperatures significantly below 20°C the insulation shrinks. This disables its easy fitting.

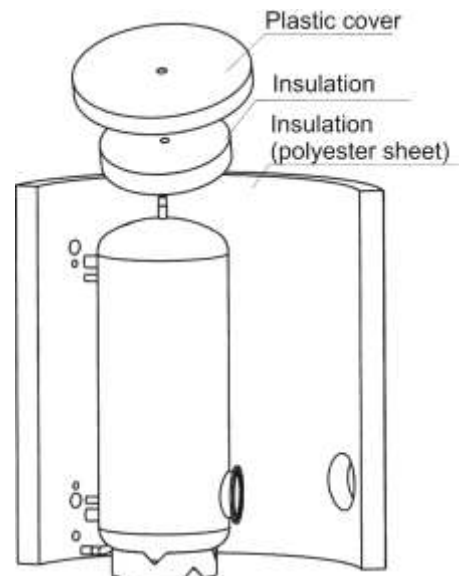

3.2 NADO 300/20v6

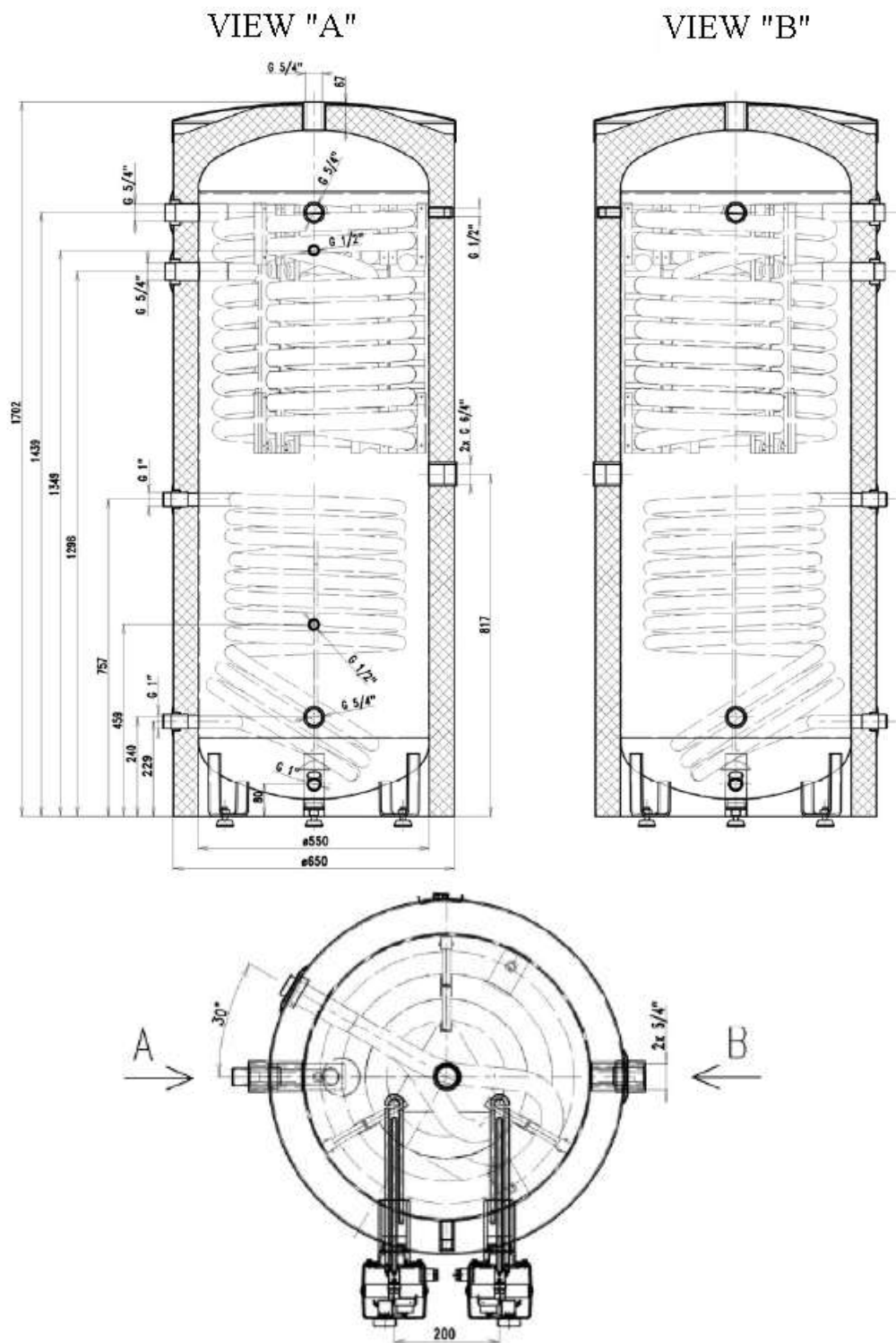

Thermal insulation: BALCALDO

22-8-2016