

OPERATING AND INSTALLATION MANUAL

TANK-TYPE WATER HEATERS FOR HORIZONTAL MOUNTING

4 kW/400 V

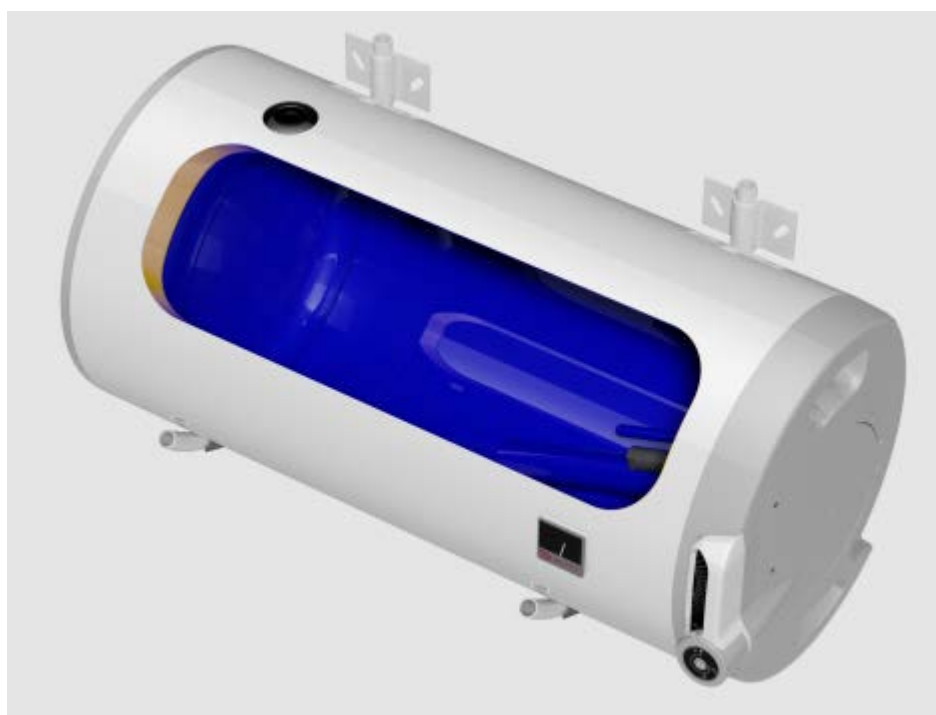

OKCV 180
OKCV 200

OKCEV 180
OKCEV 200

Družstevní závody Dražice - strojírna s.r.o.
Dražice 69, 294 71 Benátky nad Jizerou
Phone.: +420 /326 370 990
Fax: +420 / 326 370 980
e-mail: prodej@dzd.cz

 **DRAŽICE**
ČLEN SKUPINY NIBE

CONTENTS

1	PRODUCT TECHNICAL SPECIFICATION.....	4
1.1	FUNCTION DESCRIPTION	4
1.2	ADVICE FOR CUSTOMERS	4
1.2.1	HOT WATER CONSUMPTION.....	4
1.2.2	ENERGY SAVING.....	5
1.2.3	EMERGENCY POWER CONSUMPTION.....	5
1.3	DESIGN AND GENERAL HEATER DIMENSIONS.....	6
2	OPERATION AND FITTING INSTRUCTIONS.....	10
2.1	OPERATING CONDITIONS	10
2.2	WALL MOUNTING.....	10
2.3	PLUMBING FIXTURE.....	11
2.4	ELECTRICAL INSTALLATION.....	13
2.4.1	GENERAL INFORMATION FOR ELECTRICAL INSTALLATION	13
2.5	CONNECTION OF INDIRECT HEATER TO HOT WATER SYSTEM.....	14
2.6	FIRST COMMISSIONING.....	15
2.7	PUTTING OUT OF SERVICE, DISCHARGE	15
2.8	INSPECTION, MAINTENANCE & CARE FOR THE APPLIANCE	16
2.9	MOST FREQUENT FUNCTION FAILURES AND THEIR CAUSES	17
3	OPERATION OF THERMOSTAT	18
3.1	SERVICING.....	18
3.1.1	OPERATING DEVICES OF THE HEATER	18
3.1.2	TEMPERATURE SETTING	18
4	IMPORTANT NOTICES.....	19
4.1	INSTALLATION REGULATIONS.....	19
4.2	ACCESSORIES AND SPARE PARTS.....	19
4.3	DISPOSAL OF PACKAGING MATERIAL AND NON-FUNCTIONING PRODUCT.....	20

CAREFULLY READ THIS MANUAL BEFORE INSTALLING THE WATER HEATER!

Dear Customer,

The Works Cooperative of Dražice – Machine Plant, Ltd., would like to thank you for your decision to use a product of our brand. With this guide, we will introduce you to the use, construction, maintenance and other information on electrical water heaters.



The manufacturer reserves the right for engineering modification of the product. The product is designed for permanent contact with drinkable water.

It is recommended to use the product in indoor environment with air temperatures from +2°C to 45°C and a relative humidity up to 80%.

Product's reliability and safety is proven by tests implemented by the Engineering Test Institute in Brno.

Meaning of pictograms used in the Manual



Important information for heater users.



Abiding by the recommendations of the manufacturer serves to ensure trouble-free operation and the long service life of the product.



Caution!

Important notice to be observed.

1 PRODUCT TECHNICAL SPECIFICATION

1.1 FUNCTION DESCRIPTION

The heater is designed for accumulation heating of service water using electricity or thermal energy via an exchanger (for the combined design only). **Water is heated by an electric element (or a heat exchanger)** in an enamelled thermally insulated accumulator at the time defined by electricity supplier. The element is at the time of heating controlled by a thermostat the temperature of which can be adjusted continuously (within the range between 5°C and 74°C). Once the selected temperature is reached, heating interrupts automatically. **Water accumulated in the tank is then used for consumption.** The tank keeps constant pressure of water from the water main. If the combination faucet hot water valve is opened, water from the water supply conduit pressed out by cold water pressure flows out of the heater. Hot water flows out through the top part, and water flowing in remains in the bottom part of the heater. The pressure principle allows hot water withdrawal at any place from the heater (Figure 7, Figure 8).

Operation activity:

a) Water heating by electric energy

After the heater is connected to electric network, the heating element starts heating water. The element is turned on and off by a thermostat. After reaching the temperature set, the thermostat switches off the electric circuit and discontinues water heating. The control light signals if the element is in operation (light is on) or if it is off (the light goes out). In case of longer operation without using the heated volume, the thermostat has to be set to position 5°C to 8°C (set the “snowflake” symbol on the thermostat selector) to avoid its freezing, or electricity supply to the heater has to be switched off. In combined versions, the stop valve at the inlet to the exchanger has to be closed if heated with electricity which prevents heating the water in the hot water heating system.

b) Service water heating via thermal energy through heat exchanger

Closing valves of the heat exchanger must be opened which ensures heating water flow from the hot water heating system. Along with a closing valve at the inlet to the heat exchanger, it is recommended to install an air removal valve, in order to bleed the heat exchanger as needed, in particular before the beginning of the heating season. The time it takes to heat up using the heat exchanger depends on the temperature and flow of water in the hot water heating system. A combined heater is made in universal design – depending on the need of connecting the closing valves to the heating element either from the right, or from the left.

1.2 ADVICE FOR CUSTOMERS

1.2.1 HOT WATER CONSUMPTION



Consumption of hot water in households depends on the number of people, amount of sanitary equipment, length, diameter and insulation of piping in the flat, or on individual habits of users. The cheapest option of water heating comes at the time when the electricity rate is reduced.



Find out in what time intervals your electricity supplier provides reduced tariff and, depending on that information, select relevant volume and power input of the heater so that your hot water consumption covered the needs of your household.

1.2.2 ENERGY SAVING



Hot utility water reservoir is insulated by means of top-quality polyurethane foam with zero CFCs content. Adjust the temperature of the heater's thermostat to that level only that you need to run your home. Thus you will reduce electricity consumption, as well as the amount of lime sediments on the walls of the receptacle and on the heat exchanger.



If you use electronic thermostat in a mode that allows manual setting of the required temperature, then set the temperature to such that you need urgently for the operation of your household. Thus you will reduce electricity consumption, as well as the amount of lime sediments on the walls of the receptacle and on the electric element's pit.

1.2.3 EMERGENCY POWER CONSUMPTION



If no heated water is taken from the tank, a small amount of heat leaks. This loss is measured for a period of 24 hours at the temperature of 65°C in the heater, and at 20°C in its ambient area. The resulting value is expressed in units [kWh/24h] and indicates the amount of power needed to maintain the set temperature. Data sheet - see Table 1. - Tabulka 1.

HEATER TYPE	ENERGY EFFICIENCY CLASS	NOMINAL CAPACITY (L)	TIME OF CONTENT HEATING (HOURS)	ELECTRICITY CONSUMPTION FOR HEATING OF VOLUME FROM 15°C TO 65°C (kWh)
OKCV 180; OKCEV 180	C	180	2,7	10,6
OKCV 200; OKCEV 200	C	200	3	12

Table 1

1.3 DESIGN AND GENERAL HEATER DIMENSIONS

The heater tank is made of a steel plate and tested by 0.9 MPa overpressure. The heat exchanger is tested with a pressure of 1.5 MPa. The inside of the receptacle is enamelled. A flange is welded onto the bottom of the tank with a flange lid screwed to it. A sealing ring is inserted between the flange lid and the flange. Thermowells for placing a heating element and sensors of regulation thermostat and safety fuse are located in the flange lid. An anode rod is mounted onto the M8 nut. **The water reservoir is insulated by means of polyurethane foam.** Electric wiring is placed underneath the plastic removable cover. The temperature of water can be set using the thermostat. In combined versions, a heat exchanger is **welded** onto the pressure tank. The heat exchanger is only intended for the heating circuit.

Heater dimensions - (Figure 1, Figure 2) and (Table 3; Table 4).

TYPE		OKCV 180	OKCV 200
		OKCEV 180	OKCEV 200
VOLUME	L	180	200
MAX OPERATING OVERPRESSURE IN THE TANK	MPa		0,6
MAX MAXIMUM OPERATING OVERPRESSURE IN THE EXCHANGER*	MPa		0,4
ELECTRICAL CONNECTION	V	3 PE-N 400 V/50Hz	
INPUT	W	4000	
EL. PROTECTION		IP 42	
MAX HSW TEMPERATURE	°C	80	
RECOMMENDED HSW TEMPERATURE	°C	60	
HEIGHT OF THE HEATER	mm	1187	1287
DIAMETER OF THE HEATER	mm	584	584
MAX WEIGHT OF THE HEATER WITHOUT WATER	kg	80/69	84/73
TIME OF HEATING BY ELECTRICITY FROM 10°C TO 60°C	hrs	2,7	3
LOAD PROFILE		XL	XL
DAILY ELECTRICITY CONSUMPTION	kWh	19,21	19,88
MIXED WATER V40	L	266,52	301,93

TYPE		OKCV 180	OKCV 200
EXCHANGER HEAT TRANSFER SURFACE	m ²	0,75	0,75
RATED THERMAL OUTPUT AT HEATING WATER TEMPERATURE 80°C AND FLOW 720 l/h	W	18000	18000
TIME OF HEATING BY EXCHANGER FROM 10°C TO 60°C	min	38	43
RATED THERMAL OUTPUT AT HEATING WATER TEMPERATURE 80°C AND FLOW 310 l/h	W	11000	11000
TIME OF HEATING BY EXCHANGER FROM 10°C TO 60°C	min	63	72

*The OKCEV series heaters do not have a heat exchanger.

Table 2

OKCV 180, OKCV 200

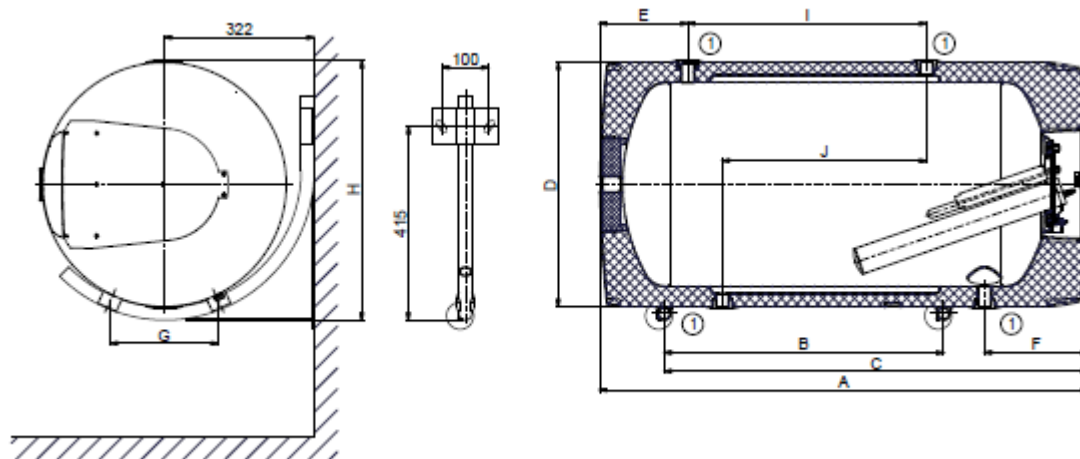

Figure 1

TYPE	OKCV 180	OKCV 200
A	1187	1287
B	600	600
C	936	936
D	584	584
E	258	258
F	246	246
G	256	256
H	618	618
I	570	670
J	439	439
1	$\frac{3}{4}$ "	$\frac{3}{4}$ "

Table 3

OKCEV 180, OKCEV 200

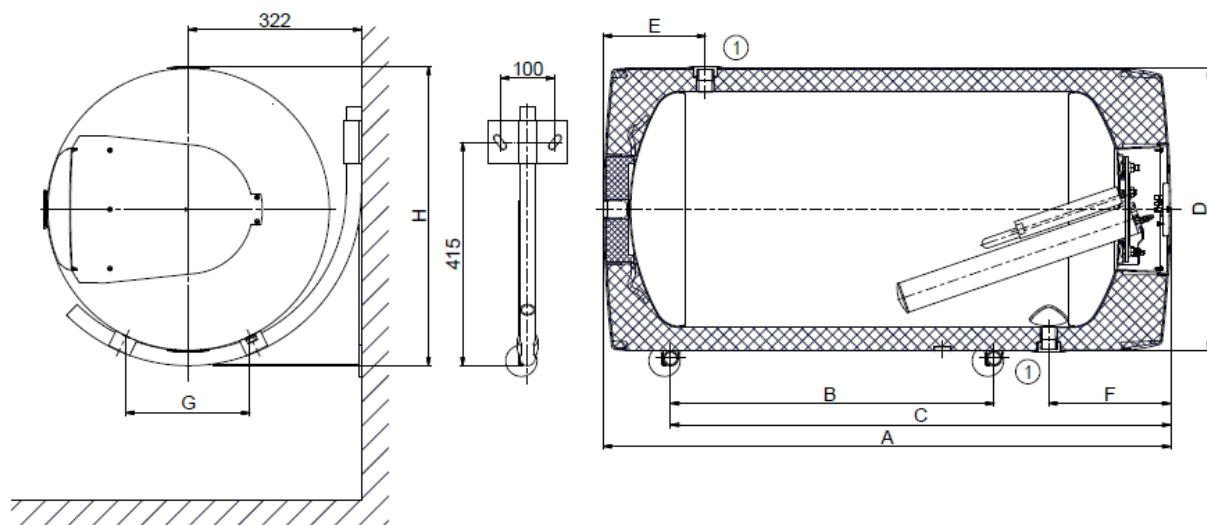

Figure 2

TYPE	OKCEV 180	OKCEV 200
A	1187	1287
B	600	600
C	897	936
D	584	584
E	258	258
F	246	246
G	252	252
H	618	618
1	3/4"	3/4"

Table 4

2 OPERATION AND FITTING INSTRUCTIONS

2.1 OPERATING CONDITIONS



The tank shall only be used in accordance with the conditions specified on the performance plate and in instructions for electric wiring. Besides legally acknowledged national regulations and standards, also conditions for connection defined in local electric and water works have to be adhered to, as well as the installation and operation manual. The room, in which the appliance will be operated, must be frost-free. The appliance has to be mounted at a convenient place, it means that the appliance must be easily available for potential necessary maintenance, repair or replacement, as the case may be.

We would like to emphasise that the heater must not be connected to power supply if work involving flammable liquids (petrol, spot remover) or gases, etc., is performed nearby.



If water is strongly calcareous we recommend that any of the common decalcifying device was installed with the appliance, or the thermostat to be set to the minimum operation temperature of 60°C. For proper operation, drinkable water of adequate quality shall be used. To avoid potential sediments we recommend that the device was installed together with a water filter.

2.2 WALL MOUNTING



Prior to mounting, check the loading capacity of the wall and, depending on the type of masonry, choose a suitable anchorage material, or reinforce the wall, if needed. The water heater shall only be mounted in horizontal position so that from the front view, the right edge of the heater was placed at least 600mm from the opposite wall. In combined and electric heaters, elbows have to be attached to the heating water inlet and outlet right before the suspension in brackets and, by turning them, the mounting either from the right or from the left has to be determined. With regard to various types of carrying masonry and broad assortment of special anchorage material available at the market, we do not provide heaters with this material. The anchorage system must be selected individually, depending on the conditions (Figure 3). We recommend an authorised company perform mounting on the wall and anchorage, or discuss the anchorage with a professional.



If the hot water heater is mounted in a **tight, smaller space**, or in an intermediate ceiling, etc., you have to make sure that the connecting side of the appliance (connections to water supply, area for electric plugging) remained accessible and no heat accumulation occurs.

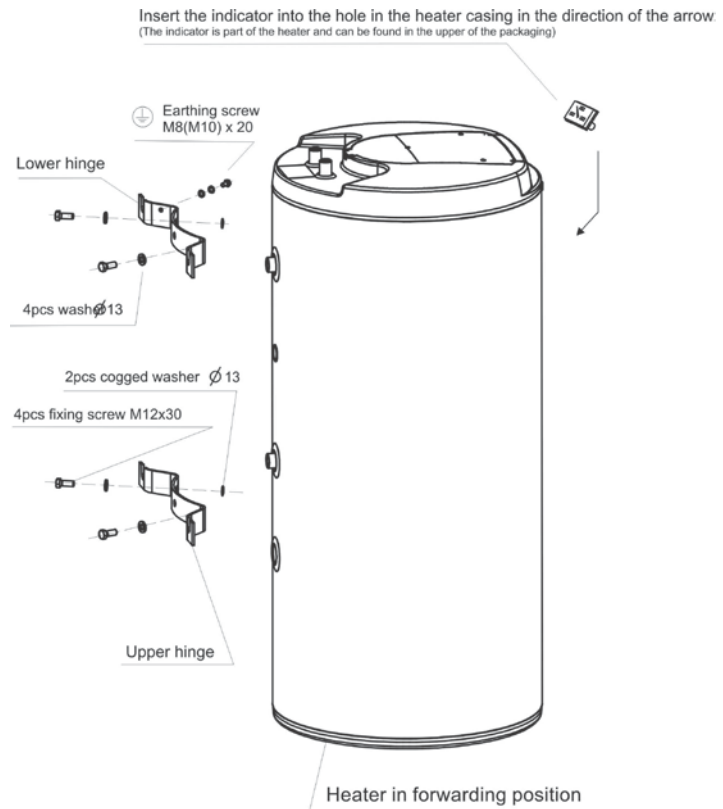

Figure 3

2.3 PLUMBING FIXTURE



Heaters are connected to plumbing fixtures as shown in Figure 4, Figure 5. For potential disconnection of the heater, the service water inlets and outlets must be provided with screw coupling Js 3/4". The safety valve is mounted on the cold water inlet identified with a blue ring.



Each hot service water pressure heater must have a safety valve with a membrane spring. Nominal clearance of safety valves is defined by standard. Heaters are not equipped with a safety valve. The safety valve must be easily accessible, as close to the heater as possible. The inlet pipes must have at least the same clearance as the safety valve. Safety valve is placed high enough to secure dripping water drain by gravity. We recommend mounting the safety valve onto a branch pipe. This allows easier exchange without having to drain the water from the heater. Safety valves with fixed pressure settings from the manufacturer are used for the assembly. The starting pressure of the safety valve must be identical with the maximum allowed heater pressure, and at least 20 % higher than is the maximum pressure in the water main (Table 5). If the water main pressure exceeds such value, a reduction valve must be added to the system. No stop valves can be put between the heater and the safety valve. During assembly, follow the guide provided by the safety equipment manufacturer.



It is necessary to check the safety valve each time before putting it into operation. It is checked by manual moving of the membrane from the seat, turning the make-and-break device button always in the direction of the arrow. After being turned, the button must click back into a notch. Proper function of the make-and-break device results in water draining through the safety valve outlet pipe. In common operation, such a check needs to be implemented at least once a month, and after each heater shutdown for more than 5 days. Water may be dripping off the drain pipe of the safety valve; the pipe must be open into the air, pointed down; environment temperatures must not drop below zero. When draining the heater, use the recommended drain valve. First, close the water supply into the heater. For proper safety valve operation, a backflow valve must be mounted on the inlet pipes, preventing spontaneous heater draining and hot water penetrating back into the water main.

Required pressures – Table 5. We recommend that the hot water distribution from the heater was as short as possible to minimise heat losses.

SAFETY VALVE STARTING PRESSURE (MPa)	ACCEPTABLE OPERATING OVER-PRESSURE OF THE WATER HEATER (MPa)	MAX COLD WATER PRESSURE IN PIPING (MPa)
0,6	0,6	up to 0.48
0,7	0,7	up to 0.56
1	1	up to 0.8

Table 5

Water heaters must be provided with a discharge valve mounted on the cold service water inlet to the heater for potential disassembly or repair.

OKCV 180 OKCV 200

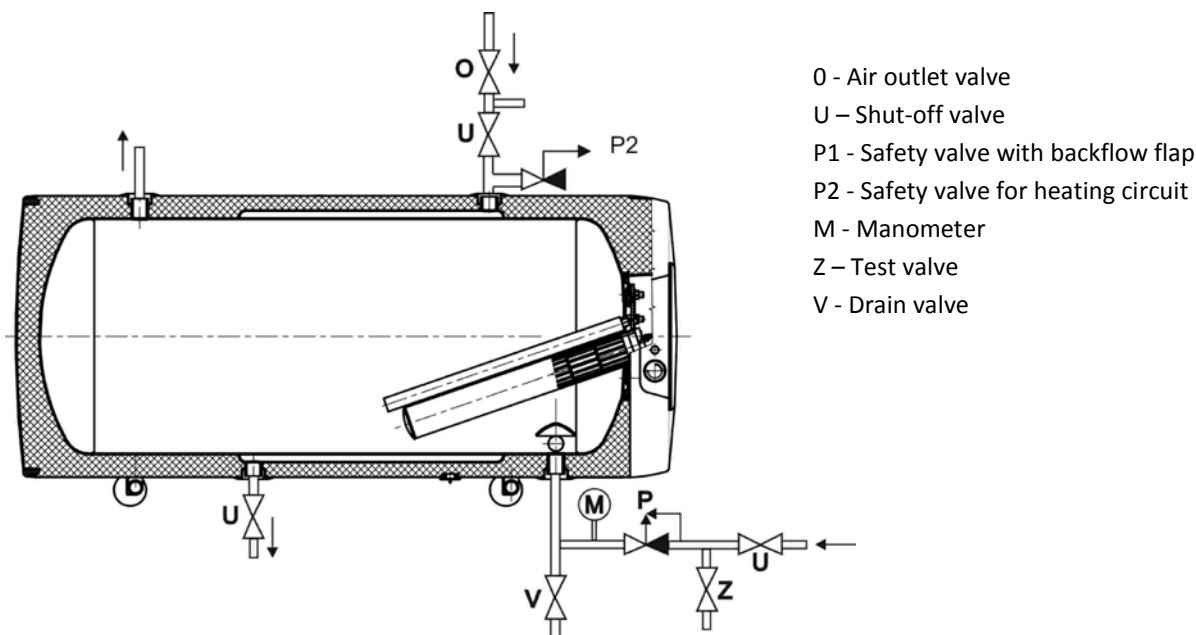

OKCEV 180, OKCEV 200

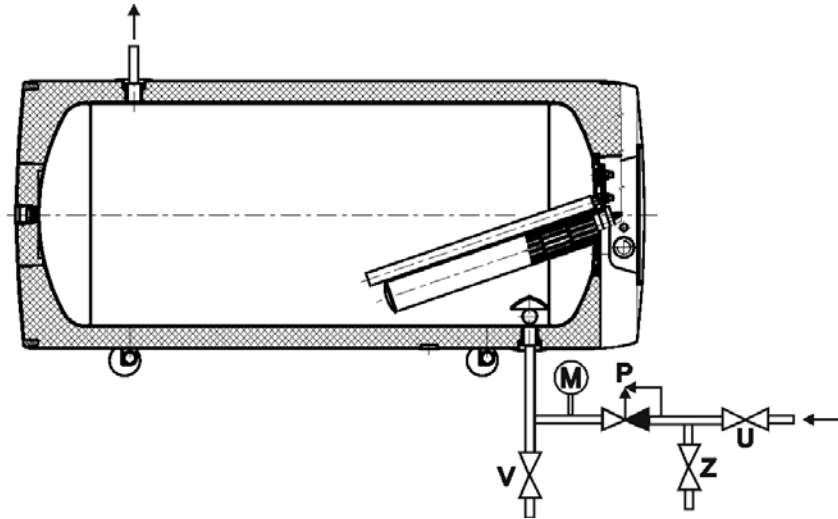

- O - Air outlet valve
- U – Shut-off valve
- P1 - Safety valve with backflow flap
- P2 - Safety valve for heating circuit
- M - Manometer
- Z – Test valve
- V - Drain valve

Figure 5

2.4 ELECTRICAL INSTALLATION

2.4.1 GENERAL INFORMATION FOR ELECTRICAL INSTALLATION



- The wiring diagram is attached to the heater on the side of the electric installation guard (see Fig. 6).
- Connection, repairs, and wiring inspections may only be implemented by a company (person) authorised to such activity.
- Expert connection must be confirmed on the warranty certificate.
- The heater is connected to the 400 V/50 Hz electric network using a fixed moving conductor with a switch that turns off all network poles and the circuit breaker (protector).
- The degree of protection of electric parts of the heater is IP 42.

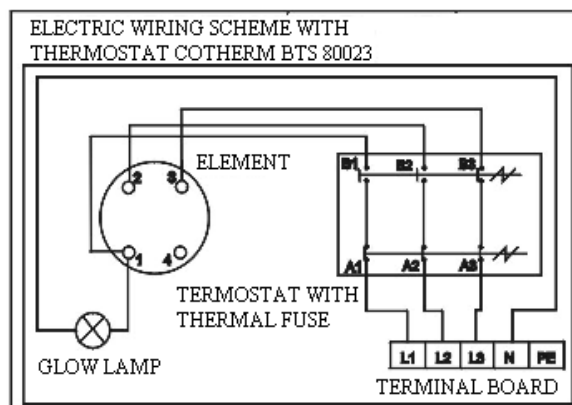

Figure 6

2.5 CONNECTION OF INDIRECT HEATER TO HOT WATER SYSTEM



It is recommended to install stop valves on the heating water inlet and outlet (for possible dismantling of the heater). Valves should be as close as possible to the heater to minimise higher heat losses (Figure 7 and Figure 8).

TANK TYPE COMBINED WATER HEATER; HOT WATER DISTRIBUTION

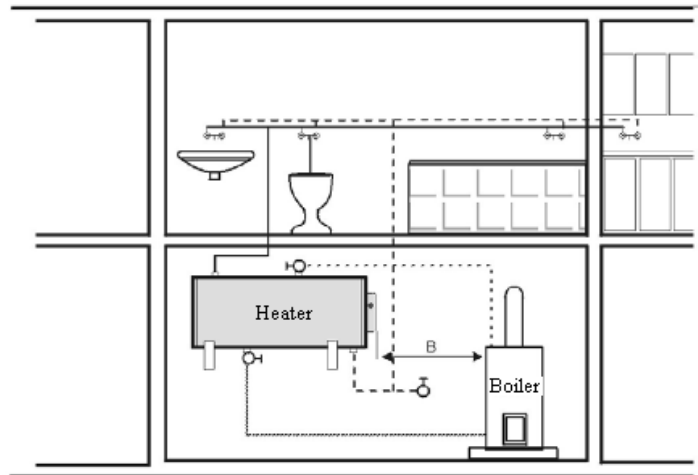
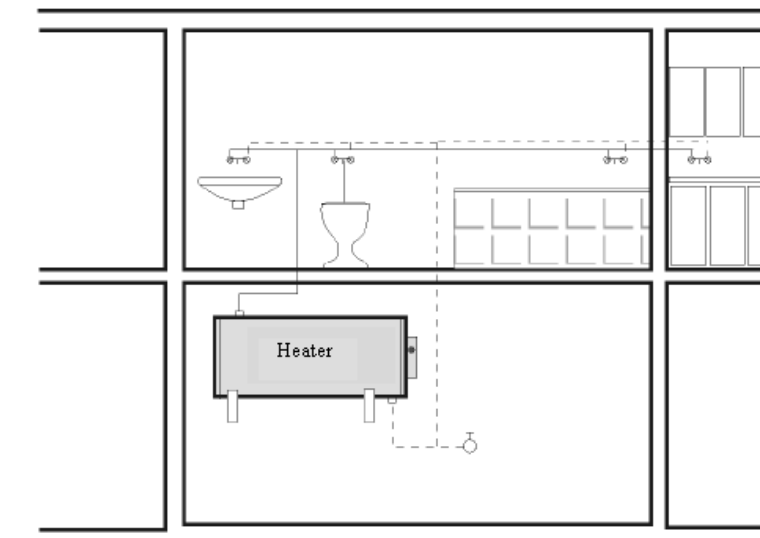

Figure 7

— Hot water
- - - Cold water
· · · Heating circuit
- · - Return circuit

TANK TYPE ELECTRIC WATER HEATER; HOT WATER DISTRIBUTION



— Hot water
- - - Cold water

Figure 8

2.6 FIRST COMMISSIONING



After connecting the heater to the water supply, the hot water heating system, the electric network, and after testing its safety valve (based on the valve manual attached), the heater may be put into operation. Before opening the power supply, the tank must be filled with water. The process of first heating must be executed by licensed professional who has to check it. Both the hot water outlet pipe and safety armature parts may be hot.



During the heating process the pressurised connection water that increases its volume due to heating must drip off the safety valve. In non-pressurised connection water drips off the overflow combination faucet. When heating is finished, the set temperature and the actual temperature of consumed water must be more-or-less the same. After connecting the heater to the water main and electrical power system, and after checking the safety valve (following the instructions attached to the valve), the heater can be put into operation.

Procedure of putting the heater into operation:

1. Check both water and electric installation; in combined heaters check also the installation to the hot water heating system. Check proper placement of operating and safety thermostat sensors. The sensors must be inserted all the way in; first the operating and then the safety thermostat.
2. Open the hot water valve on the combination faucet.
3. Open the cold water inlet valve to the heater.
4. As soon as the water starts running through the hot water valve, the heater is filled and the valve can be closed.
5. In case of leakage (of flange lid), we recommend that the flange lid bolts are fastened.
6. Screw down the electric installation guard.
7. When hot sanitary water is heated by electric energy, switch on the power supply (the valve on the heating water inlet to the heating insert must be closed in combined heaters).
8. When sanitary water is heated with electric energy from the hot water heating system, turn off electricity an open the valves on the heating water inlet and outlet, possibly de-aerate the exchanger.
9. When commencing operation, flush the heater until the cloudiness in the water is gone.
10. Make sure to fill in properly the warranty certificate.

2.7 PUTTING OUT OF SERVICE, DISCHARGE



If the hot water heater is put out of service for a longer time, or if it is not going to be used it has to be drained and disconnected from the electric supply network on all poles. The switch for the supply lead or the fuse cut-outs have to be shut off.

At places with permanent risk of frost the hot water heater must be drained before the cold season starts if the appliance remains out of service for several days and if the power supply is disconnected.



Drainage of utility water shall be performed after closing the shut-off valve in the cold water supply piping (through the discharge valve for safety valve combination), and with simultaneous opening of all hot water valves of connected fittings. **Hot water may outflow during the drainage!** If there is a risk of frost it has to be considered that not only the water in the hot water heater and in the hot water piping may get frozen but also the water in the entire cold water supply piping. It is therefore advisable to drain all fittings and piping that carry water, up to the part where the house water meter is installed (connection of the house to water main) which is not jeopardised by frost. When the tank is to be used again, it has to be filled with water and one needs to make sure that the **water flowing out at the hot water valves did not contain any bubbles.**

2.8 INSPECTION, MAINTENANCE & CARE FOR THE APPLIANCE



During the heating process the water that increases its volume during the heating must drip off the safety valve outlet (in non-pressurised connection this water drips off the combination faucet valve). In full heating (about 65°C) the volumetric water gain is approx. 3% of the tank capacity. The function of the safety valve has to be checked regularly (based on the information contained in the attached safety valve manual). In common operation, such a check needs to be implemented at least once a month, and after each heater shutdown that exceeds 5 days.

Caution! In doing so, the cold water supply pipe and the connection fitting of the tank may get heated! If the hot water heater does not work, or if hot water is not withdrawn, no water shall drip off the safety valve. If water drips, then the pressure in the supply piping is either too high, or the safety valve is defective. Please call a specialised plumber immediately!



If water contains too many minerals, an expert has to come to remove the scale that forms inside the tank, as well as free sediments. This has to be performed after one or two years of operation. Repeated heating causes lime scale settling on the receptacle walls and mostly on the lid of the flange. Lime scale settling depends on hardness of heated water, its temperature and on the volume of hot water used.

We recommend checking and cleaning the tank from lime scale and eventual replacement of the anode rod after two years of operation. The anode life is theoretically calculated for two years of operation; however, it changes with water hardness and chemical composition in the place of use. Based on such an inspection, the next term of anode rod exchange may be determined. Have a company in charge of service affairs deal with the cleaning and exchanging of the anode.

When draining water from the heater, the combination faucet valve for hot water must be open, preventing the occurrence of under-pressure in the heater tank which would stop water from draining. Cleaning is carried out through the hole in the flange by: draining the boiler, dismantling the flange lid and cleaning the tank. A new sealing has to be used for re-fitting. Since the inside of the heater has special enamel, the surface of which must not get in contact with a scale removing agent – do not work with a lime pump. Remove the lime layer with a timber and suck it off, or wipe it off with a clout. After that, the appliance must be

rinsed thoroughly and the heating process is checked the same as during the initial putting in operation. Do not use any abrasive cleaning agents or dye thinners to clean the outer shell of the heater (such as cellulose thinner, trichlor, and the like). For cleaning use a wet clout and add a few drops of liquid cleaning agent for household applications.

2.9 MOST FREQUENT FUNCTION FAILURES AND THEIR CAUSES

Other potential failures – Table 6.

FAILURE SYMPTOM	INDICATOR	SOLUTION
Water is cold	<ul style="list-style-type: none"> • Light on 	<ul style="list-style-type: none"> • The temperature set on the thermostat is too low • Heating element failure
Water is cold	<ul style="list-style-type: none"> • Light off 	<ul style="list-style-type: none"> • no service cable • Thermostat failure • Safety thermostat shut off probably due to failed operation thermostat
Water is not warm enough	<ul style="list-style-type: none"> • Light on 	<ul style="list-style-type: none"> • failure of one of the coils in the element (consists of two)
Temperature of water is not corresponding with the set value		<ul style="list-style-type: none"> • Defective thermostat
Water is constantly dripping off the safety valve	<ul style="list-style-type: none"> • Light off 	<ul style="list-style-type: none"> • high input pressure • defective safety valve

Table 6



Do not attempt to repair the failure yourselves. Seek either expert or service help. It does not take much for an expert to remove the defect. When making a repair appointment, report the type and serial number you find on the performance plate of your water heater.

3 OPERATION OF THERMOSTAT

3.1 SERVICING

3.1.1 OPERATING DEVICES OF THE HEATER

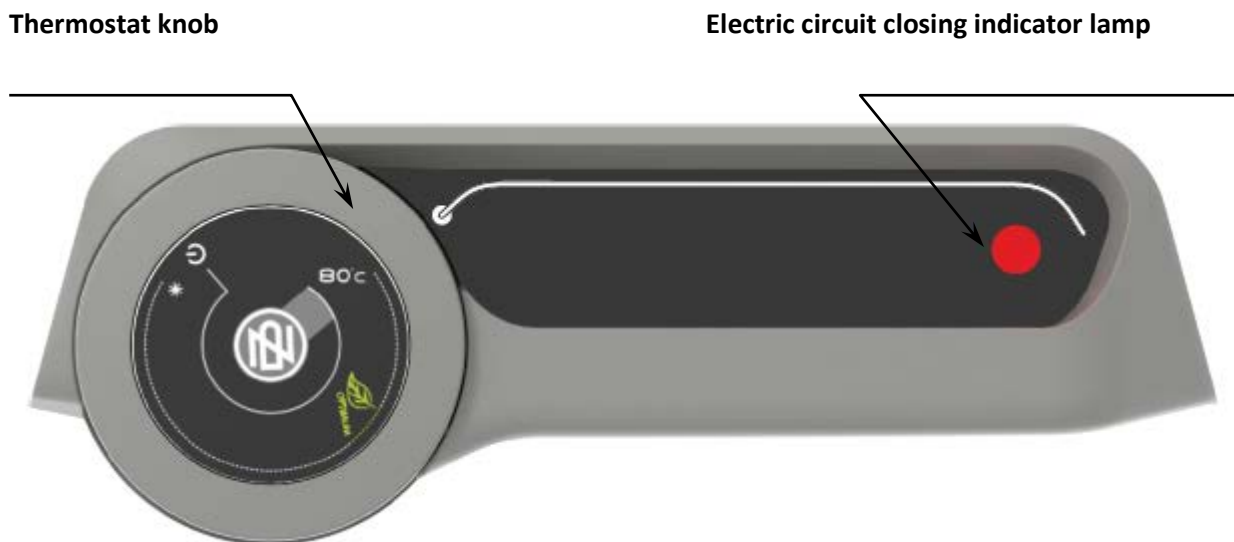

Figure 9

3.1.2 TEMPERATURE SETTING

Water temperature is set by turning the thermostat knob. The desired symbol is adjusted against the fixed point on the control panel (Figure 10).



Figure 10



Adjusting the thermostat knob to the left backstop does not mean permanent shutoff of the heating element. When the heater is in use without blocking the daily rate, we do not recommend the temperature to be set above 55°C. Select the "ECO" symbol as the maximum.

4 IMPORTANT NOTICES

4.1 INSTALLATION REGULATIONS

- **Without a confirmation of performed electrical installation issued by an authorised company, the warranty certificate shall be void.**
- Check and exchange the Mg anode regularly.
- You have to apply for approval of a local power supplier to connect the heater.
- **No stop valves can be put between the heater and the safety valve.**
- If the overpressure in the water main exceeds 0.48 MPa, a pressure control valve must be mounted before the safety valve.
- All hot water outputs must have a combination faucet.
- Before filling the heater with water for the first time, it is recommended to fasten the flange connection nuts of the tank.
- It is not allowed to handle the thermostat, aside from temperature resetting with a control button.
- All electric installation handling, adjustment and replacement of the regulation elements shall only be performed by an authorised service company.
- **The thermal fuse must not be turned off!** In case of thermostat defect, the thermal fuse interrupts electric power input to the heating element if the water temperature in the heater exceeds 90 °C.
- As an exception, the thermal fuse may also switch off due to water overheating caused by overheating the hot water heating system boiler (in case of a combined heater).
- **We recommend you operate the heater with one type of energy.**



Both the electric and water installation must follow and meet the requirements and regulations relevant in the country of use!

4.2 ACCESSORIES AND SPARE PARTS

The product is supplied with a safety valve, thermometer, wall mounting heater suspension elements - brackets (bent reinforced tubes). The above parts are packed and placed in the packaging in the top part of the heater. Also other fastening elements - hinges - can be purchased separately with the heater. It is a set of two hinges and bolts to fasten them to the heater, and an earthing bolt. The catalogue number of this set is 102000702.

It is in your own interest to check the completeness of the accessories.

4.3 DISPOSAL OF PACKAGING MATERIAL AND NON-FUNCTIONING PRODUCT

A service fee for providing return and recovery of packaging material has been paid for the packaging in which the product was delivered. The service fee was paid pursuant to Act No 477/2001 Coll., as amended, at EKO-KOM a.s. The client number of the company is F06020274. Take the water boiler packages to a waste disposal place determined by the town. When the operation terminates, disassemble and transport the discarded and unserviceable heater to a waste recycling centre (collecting yard), or contact the manufacturer.



31-3-2016