

OPERATING AND INSTALLATION MANUAL

STATIONARY HOT WATER TANKS

OKF 200 NTR/S
OKF 250 NTR/S
OKF 300 NTR/S



Družstevní závody Dražice-strojírna s.r.o.
Dražice 69, 294 71 Benátky nad Jizerou
tel.: +420 / 326 370 911
e-mail: export@dzd.cz

 **DRAŽICE**
NIBE GROUP MEMBER

CONTENTS

1	PRODUCT TECHNICAL SPECIFICATION.....	4
1.1	FUNCTION DESCRIPTION.....	4
1.2	OPERATING AND INSTALLATION MANUAL FOR TYPES: OKF 200 NTR/S, OKF 250 NTR/S, OKF 300 NTR/S	4
1.2.1	PRODUCT DESCRIPTION.....	4
1.2.2	CONSTRUCTION AND BASIC DIMENSIONS OF TANK.....	5
1.2.3	TECHNICAL PARAMETERS.....	7
2	OPERATION AND FITTING INSTRUCTIONS.....	8
2.1	OPERATING CONDITIONS.....	8
2.2	ADDITIONAL ELECTROINSTALLATION	8
2.3	PLUMBING FIXTURE	8
2.4	PRESSURE LOSSES	10
2.5	EXAMPLES OF TANKS CONNECTION	11
2.6	FIRST COMMISSIONING	12
2.7	TANK CLEANING AND ANODE ROD EXCHANGE	12
2.8	SPARE PARTS.....	13
3	IMPORTANT NOTICES.....	14
3.1	INSTALLATION REGULATIONS.....	14
3.2	TRANSPORT & STORAGE INSTRUCTIONS.....	15
3.3	DISPOSAL OF PACKAGING MATERIAL AND NON-FUNCTIONING PRODUCT	15

CAREFULLY READ THIS MANUAL BEFORE INSTALLING THE WATER HEATER!

Dear Customer,

Družstevní závody Dražice - strojírna s.r.o., would like to thank you for your decision to use a product of our brand. With this guide, we will introduce you to the use, construction, maintenance and other information on electrical water heaters.



The product is not intended to be controlled by

- a) people (including children) with reduced physical, sensual or mental capacities, or
- b) people with insufficient knowledge and experiences unless supervised by responsible person, or unless properly instructed by such responsible person.

The manufacturer reserves the right for engineering modification of the product. The product is designed for permanent contact with drinkable water.

It is recommended to use the product in indoor environment with air temperatures from +2 °C to +45 °C and a relative humidity up to 80 %.

Product's reliability and safety is proven by tests implemented by the Engineering Test Institute in Brno.

Made in the Czech Republic.

Meaning of pictograms used in the Manual



Important information for heater users.



Abiding by the recommendations of the manufacturer serves to ensure trouble-free operation and the long service life of the product.



Caution!
Important notice to be observed.

1 PRODUCT TECHNICAL SPECIFICATION

1.1 FUNCTION DESCRIPTION

Thanks to their construction and number of variants, the OKF 200 - 300 NTR/S series water tanks enable economic preparation of hot service water (HSW) by means of various power sources. Their nominal performance provides sufficient amount of hot water for flat units, premises, restaurants, and similar establishments. OKF products 200 - 300 NTR/S are specially developed for DHW heating in combination with electricity from surplus PV power and reheating with a gas condensing boiler.

Service water heating via thermal energy through heat exchanger

Closing valves of the heat exchanger must be opened which ensures heating water flow from the hot water heating system. Together with a closing valve, it is recommended to install an air outlet valve at the inlet to the heat exchanger in order to bleed the heat exchanger as needed, in particular before the beginning of the heating season. The time it takes to heat up using the heat exchanger depends on the temperature and flow of water in the hot water heating system.

1.2 OPERATING AND INSTALLATION MANUAL FOR TYPES: **OKF 200 NTR/S, OKF 250 NTR/S, OKF 300 NTR/S**

1.2.1 PRODUCT DESCRIPTION

The tank receptacle is welded from a steel plate; the exchangers from a steel tube and, as a unit, it is entirely coated with hot water resistant enamel. For additional corrosion protection a magnesium anode is mounted in the upper part of the tank to adjust the electric potential inside the tank, reducing the risk of corrosion. The vessels have outlets of hot and cold water and a circulation opening welded to them. At the tanks on the side under the plastic cover, there is a cleaning and revision opening ended with a flange; various performance heating TPK 210-12 units may be mounted into the opening. The tanks 200 – 300 l includes opening G 6/4" which enables the assembly of heating unit series TJ G 6/4". Such version is used when the tank is connected in solar system or a system with a heat pump, to heat water in the upper part of the tank to the temperature required. The tank is placed on the ground, next to the heating water source, or in its vicinity. The tank and heat exchanger are made of a steel plate and tested by 1.5 multiple of the operating pressure values. Temperature indicator is placed on the heater's housing.

The NTR/S version has a heat exchanger located at the top part of the tank, and one heating water source is used for heating.

The NTR/S series do not have a heating element. The tank cannot be used for flow heating of hot water in an exchanger.

OKF 200 NTR/S, OKF 250 NTR/S

The tank is insulated with 42 mm of polyurethane foam. The heater housing is made of steel sheet provided with a powder coating.

OKF 300 NTR/S

The tank is insulated with 60 mm of polyurethane foam. The plastic housing (reinforced with polystyrene) is fitted on the tank.

1.2.2 CONSTRUCTION AND BASIC DIMENSIONS OF TANK

OKF 200 NTR/S, OKF 250 NTR/S

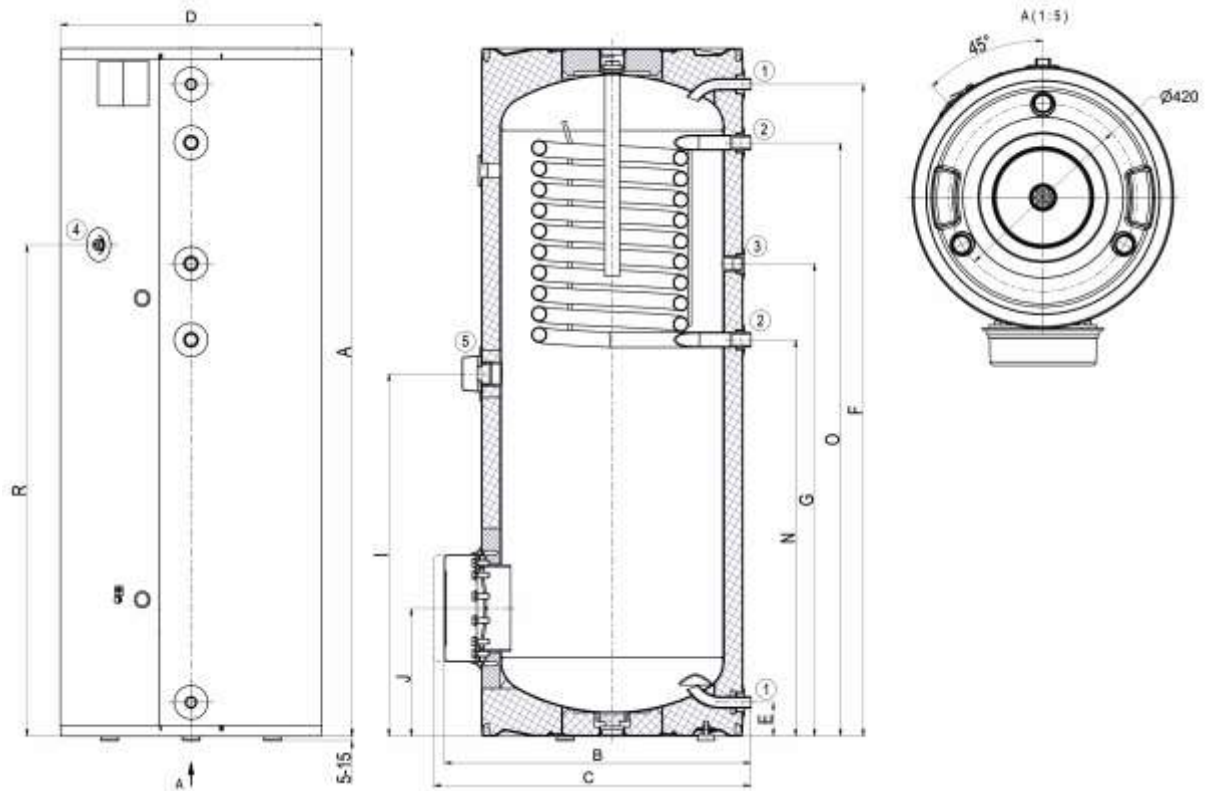

Figure 1

	OKF 200 NTR/S	OKF 250 NTR/S		
			①	3/4" outer
A	1355	1535	②	1" outer
B	685	685	③	3/4" inner
C	710	710	④	1/2" inner
D	584	584	⑤	6/4" inner
E	75	75		
F	1275	1455		
G	855	1055		
I	655	810		
J	285	285		
L	205	205		
N	705	885		
O	1145	1145		
R	915	915		

Table 1

OKF 300 NTR/S

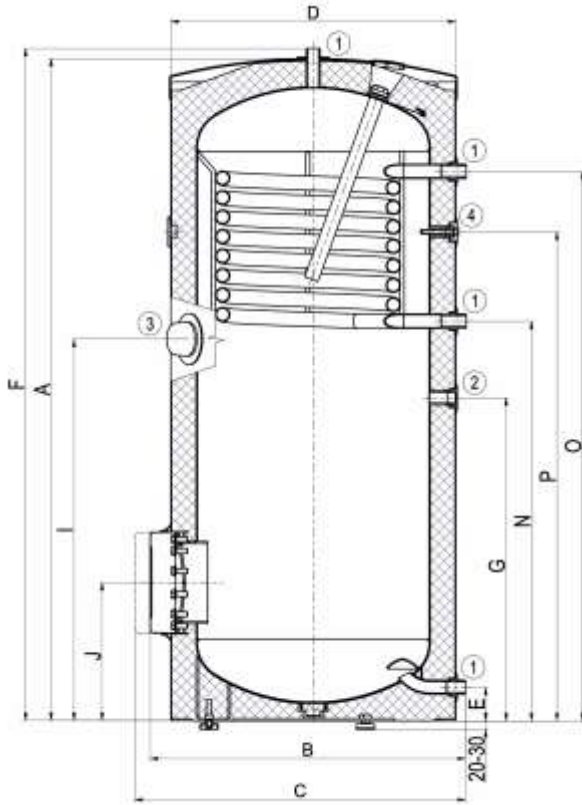

Figure 2

OKF 300 NTR/BP	
A	1558
B	750
C	810
D	670
E	79
F	1579
G	760
I	895
J	325
N	939
O	1290
P	1149

①	1" outer
②	1/2" inner
③	3/4" inner
④	6/4" inner

Table 2

1.2.3 TECHNICAL PARAMETERS

MODEL		OKF 200 NTR/S	OKF 250 NTR/S	OKF 300 NTR/S
VOLUME	l	208	242	296
WEIGHT WITHOUT WATER	kg	92	94	108
MAXIMUM TANK PRESSURE	bar		6	
OPERATING EXCHANGER PRESSURE	bar		10	
MAX. TEMPERATURE OF HEATING WATER	°C		110	
WARM WATER MAXIMUM TEMPERATURE	°C		80	
HEATING SURFACE OF UPPER EXCHANGER	m ²	1	1	1
OUTPUT OF UPPER EXCHANGER AT HEATING WATER TEMPERATURE OF 80 °C AND FLOW 720 l/h	kW	24	24	24
TIME OF HEATING BY UPPER EXCHANGER FROM 10°C TO 60 °C	min	14	14	16
ENERGY EFFICIENCY CLASS			C	
STATIC LOSSES	W	82	87	83

Table 3

2 OPERATION AND FITTING INSTRUCTIONS

2.1 OPERATING CONDITIONS



The tank shall only be used in accordance with the conditions specified on the power plate and in instructions for electric wiring. The cold water inlet of each individually closable heater must be fitted with a seal, test tap or plug to check the non-return valve, as well as a non-return valve and safety valve. Heaters with a volume of more than 200 liters must also be fitted with a pressure gauge. Besides the legally acknowledged national regulations and standards, also conditions for connection defined in the local electric and water works have to be adhered to, as well as the installation and operation manual.

The temperature at the place of the tank installation must be higher than +2°C; and the room must not freeze. The appliance has to be mounted at a convenient place; it means that the appliance must be easily available for potential necessary maintenance, repair or replacement, as the case may be.



If water is strongly calcareous, we recommend that any of the common decalcifying devices was installed in front of the tank, or that the thermostat was set to the maximum operating temperature of 60 °C (setting to position "60"). For proper operation, drinkable water of adequate quality shall be used.



300 liter volume tanks are screwed onto the bottom wooden palette with M12 screws. When the tank is released from the pallet and prior to its putting into operation, 3 screw legs supplied have to be installed as the product accessories. With three adjustable legs, the tank may be positioned vertically to the base within 10 mm range.

2.2 ADDITIONAL ELECTROINSTALLATION

There is a possibility to install additional electrical heating element (TJ or TPK).

Concrete possibilities of the installation, you can find in our catalogues (tables of the heating elements/tanks in the last pages) or at www.dzd.cz/en

2.3 PLUMBING FIXTURE



Pressure water connects to pipes with 3/4" thread valid for 200 -250 litres, G 1" valid for 300 litres. Blue - cold water supply, red - hot water outlet. For potential disconnection of the tank, utility water inlets and outlets must be provided with Js 3/4" screw coupling. The safety valve is mounted on the cold water inlet identified with a blue ring.



Every hot utility water pressure tank shall be equipped with membrane spring loaded with safety valve. Nominal clearance of safety valves is defined by standard. Safety valve shall be easily accessible, fitted as close as possible to the tank. The inlet pipes must have at least the same clearance as the safety valve. Safety valve is placed high enough to secure dripping water drain by gravity. We recommend mounting the safety valve onto a branch pipe. Easier exchange without the necessity of draining water from the tank. Safety valves with fixed pressure settings from the manufacturer are used for the assembly. Starting pressure of a safety valve must be identical to the maximum allowed tank pressure, and at least 20 % higher than the maximum pressure in the water main. If the water main pressure exceeds such value, a reduction valve must be added to the system. No closing armature may be mounted between the tank and the safety valve. During assembly, follow the guide provided by the safety equipment manufacturer.



It is necessary to check the safety valve each time before putting it into operation. It is checked by manual moving of the membrane from the seat, turning the make-and-break device button always in the direction of the arrow. After being turned, the button must click back into a notch. Proper function of the make-and-break device results in water draining through the safety valve outlet pipe. In regular operation, such a check needs to be carried out at least once a month, and after each shutdown of the tank longer than 5 days. Water may be dripping off the drain pipe of the safety valve; the pipe must be open into the air, pointed down; environment temperatures must not drop below zero. When draining the tank, use the recommended drain valve. First of all, close water inlet in the tank.

Find necessary pressure values in the table below. For proper safety valve operation, a backflow valve shall be mounted on the inlet pipes, preventing spontaneous heater draining of the tank and hot water penetration back into the water main. We recommend that the hot water distribution from the tank was as short as possible to minimize heat losses. At least one demountable joint must be mounted between the tank and every supply pipe.

Adequate piping and fittings with sufficiently dimensioned maximum temperature and pressure values must be used.

The tanks must be provided with a discharge valve mounted on the cold service water inlet to the tank for potential disassembly or repair.

When assembling the security equipment, follow the standard.

SAFETY VALVE START-UP PRESSURE [bar]	ACCEPTABLE OPERATING OVER-PRESSURE OF WATER TANK [bar]	MAXIMUM PRESSURE IN COLD WATER PIPES [bar]
6	6	up to 4,8

Table 4

2.4 PRESSURE LOSSES

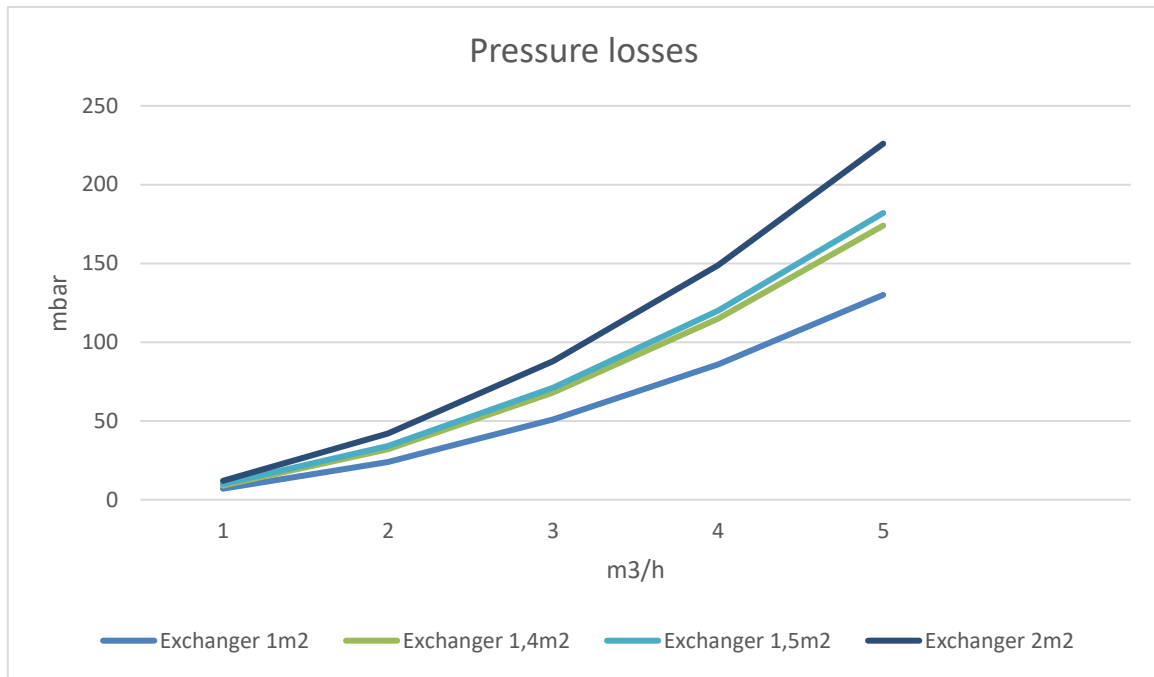

Figure 3

Type	Pressure loss [mbar] t _{HV} = 60 °C				
	Amount of heating water in m ³ /h				
	1	2	3	4	5
Exchanger 1m²	7	24	51	86	130
Exchanger 1.4m²	9	32	68	115	174
Exchanger 1.5m²	10	34	71	120	182
Exchanger 2m²	12	42	88	149	226

Table 5

2.5 EXAMPLES OF TANKS CONNECTION

Connecting a tank to the heating circuit

The tank is placed on the ground, next to the heating source, or in its vicinity. The heating circuit shall be connected to marked tank exchanger inputs and outputs, and bleeder valve installed at the highest point. It is necessary to install a filter into the circuit in order to protect pumps, three-way valve, backflow flaps and the exchanger from sedimentation. It is recommended to flush the heating circuit before the assembly. All wiring connections must be properly insulated from heat.

If the system works with priority heating of TUV (warm utility water) using a three-way valve, always follow the installation instructions of the three-way valve's manufacturer.

Connecting the tank to a Hot Water Distribution

Cold water shall be connected to an inlet marked with a blue ring and writing "HSW INLET". Hot water shall be connected to an outlet marked with a red ring or writing "HSW INLET". If the hot sanitary water (HSW) distribution is equipped with circulation circuit, it shall be connected to the outlet marked with "CIRCULATION". For potential drain of the tank, the HSW inlet has to be provided with a "T" plumbing with a drain valve. Each individually lockable tank must be on the cold water inlet provided with a stop gate, test tap, safety valve with a reverse flap and a pressure gauge.

An example of a group tank connection for steady hot water consumption from all tanks using Tichelmann's method

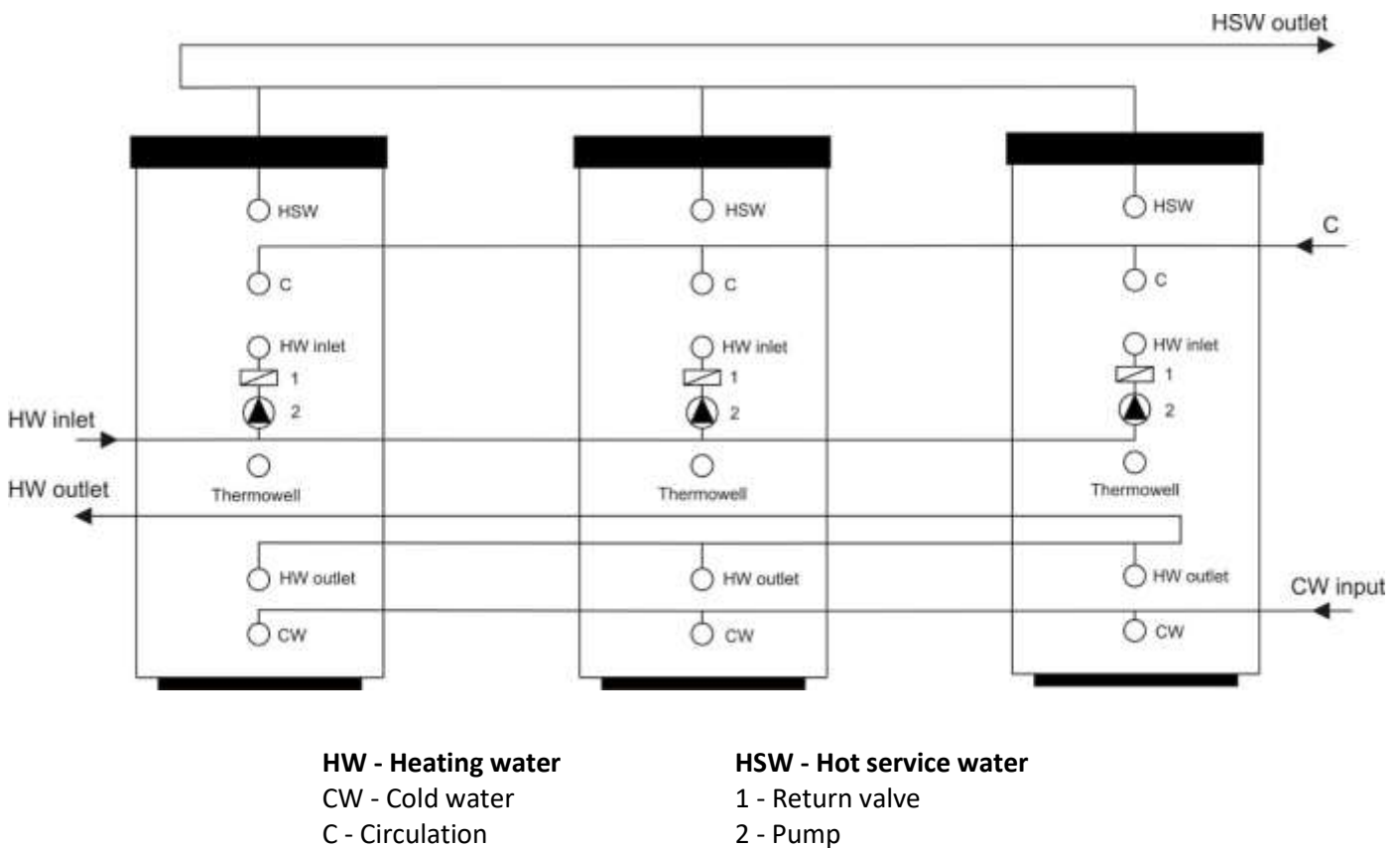

Figure 4

Heater with volume exceeding 200 liters at the outlet hot water piping provide combined temperature and pressure safety fittings according to ČSN EN 1490, or the temperature safety fittings fitted with water temperature sensor placed in the heater or other safety valves DN 20, and the opening overpressure compliant with the maximum operating overpressure of the heater vessel. The safety valve does not replace the safety valve on the cold water inlet. No closing, return armature, and filter may be mounted between the heater and the safety valve.

2.6 FIRST COMMISSIONING

Once the tank is connected to water supply system and power supply, and the safety valve tested (accordingly with the manual attached to the valve), the tank can be put in operation. Before opening the power supply, the tank must be filled with water. The process of first heating must be executed by licensed professional who has to check it. Both the hot water outlet pipe and safety armature parts may be hot.

Procedure:

- a) Check the water main and wiring; Check proper placement of thermostat sensors. Sensors has to be installed in to the sink as deep as possible - following the possibilities of each capillary, controlling thermostat has to be installed as first sensor in to the capillary, following by the safety thermostat as the second sensor installed in to the capillary;
- b) Open the hot water valve on the combination faucet;
- c) Open the cold water inlet valve to the tank.
- d) When the water starts flowing through the hot water valve, the filling of the tank is finished and the valve needs to be closed;
- e) If a flange lid leak is discovered, the flange lid bolts need to be tightened. Screws has to be tightened by cross, tightening moment 15 Nm;
- f) Fasten the electric installation cover;
- g) When heating service water heating by electric energy, turn on the electricity (for combined tanks, the heating water inlet to the heating insert must be closed);
- h) When heating the water with thermal energy from a hot water heating system, turn off the electricity and open the valves at the inlet and outlet of heating water or bleed the exchanger.
- i) Once the operation restarts, keep flushing the tank until the cloud disappears.
- j) Make sure to fill in properly the warranty certificate.

2.7 TANK CLEANING AND ANODE ROD EXCHANGE

Repetitive water heating causes limestone sediment on both the enameled tank walls and chiefly the flange lid. Lime scale settling depends on hardness of heated water, its temperature and on the volume of hot water used.



We recommend checking and cleaning the tank from scale and eventual replacement of the anode rod after two years of operation.

The anode life is theoretically calculated for two years of operation; however, it changes with water hardness and chemical composition in the place of use. Based on such an inspection, the next term of anode rod exchange may be determined. Have a company in charge of service affairs deal with the cleaning and exchanging of the anode. When draining water from the tank, the combination faucet valve for hot water must be open, preventing the occurrence of under-pressure in the tank receptacle which would stop water from draining.



To prevent the occurrence of bacteria (e.g. Legionella pneumophila) within stack heating it is recommended, if absolutely necessary, to increase the temperature of hot service water (HSW) periodically for a transitional period of time to at least 70 °C. It is also possible to make use of another way of disinfecting HSW.

PROCEDURE OF EXCHANGING ANODE ROD IN UPPER HEATER PART

1. Turn off control voltage to the tank
2. Drain water from 1/5 tank.
PROCEDURE: Close water inlet in the tank
Open the hot water valve on the combination faucet.
Open the drain tap of the tank
3. Anode is screwed in under the plastic cover in the upper lid of the tank
4. Unscrew the anode using adequate wrench
5. Pull the anode out and follow reversed steps to install a new one
6. During the fitting, make sure the grounding cable (300 l) is connected properly; this is the condition of the anode's proper functioning
7. Fill the tank with water

2.8 SPARE PARTS

- | | | |
|-------------------------------|-------------------------------------|-------------------------------------|
| - flange lid | - flange lid seal | - insulation flange lid |
| - thermostat and thermal fuse | -magnesium anode | - control button for the thermostat |
| - control lights with wires | - orientation temperature indicator | - set of M12 (or M10) bolts |

When ordering spare parts always state the name of the part, the type and type number from the tank's plate.

3 IMPORTANT NOTICES

3.1 INSTALLATION REGULATIONS



Without a proof issued by a professional company about performed electrical and plumbing fixture the warranty shall be void.

It is necessary to check the protective magnesium anode periodically and replace it if necessary.

No closing armature may be mounted between the tank and the safety valve.

If the overpressure in the eater main exceeds 0.48 MPa, a reduction valve must be mounted before the safety valve.

All outlets of hot water must be equipped with combination faucets.

Prior to the first filling the tank with water we recommend that the receptacle's flange connection nuts are tightened. Screws has to be tightened by cross, tightening moment 15Nm.

It is not allowed to handle the thermostat, aside from temperature resetting with a control button.

All electric installation handling, setting, and regulation feature exchange, may only be implemented by a service company.

The thermal fuse must not be turned off! In case of a thermostat defect, the thermal fuse interrupts electric power supply to the heating element if the water temperature in the tank exceeds 95 °C.

As an exception, the thermal fuse may also switch off due to water overheating caused by overheating the hot water heating system boiler (in case of a combined tank).

If you don't use the heater (hot water tank) for longer than 24 hours, or if the facility with heater is unattended, close the cold water inlet to the heater.

The heater (hot water tank) shall be used exclusively in accordance with the conditions specified on the performance plate and in the instructions for electric wiring.



Both the electric and water installation must follow and meet the requirements and regulations relevant in the country of use!

3.2 TRANSPORT & STORAGE INSTRUCTIONS

The device shall be transported and stored in dry place and protected from weather effects with temperature range from -15 to +50 °C. During loading and unloading the instructions stated on the packaging shall be observed.



Due to the transport and thermal dilating, excessive enamel may fall of the heaters with exchangers on the tank bottom. This occurrence is common and has no effects on the heater's service life and quality. The decisive enamel layer which remains in the vessel. DZD has many years of experience with this occurrence and it is not a reason for complaints.

3.3 DISPOSAL OF PACKAGING MATERIAL AND NON-FUNCTIONING PRODUCT

A service fee for providing return and recovery of packaging material has been paid for the packaging in which the product was delivered. The service fee was paid pursuant to Act No 477/2001 Coll., as amended, at EKO-KOM a.s. The client number of the company is F06020274. Take the water tank packages to a waste disposal place determined by the municipality. When the operation terminates, disassemble, and transport the discarded and unserviceable heater to a waste recycling center (collecting yard), or contact the manufacturer.



29-2-2024